



Z Technology
R-505C
FIELD STRENGTH METER
USER MANUAL

Dec 2001
Z Technology, Inc.
1815 NW 169th Place Suite 3070
Beaverton, OR 97006 USA
Tel: 503-614-9800 Fax: 503-614-9898

WARRANTY

Z Technology Inc. warrants to its Customers that the products it manufactures and sells will be free from defects in materials and workmanship for a period of one (1) year from the date of delivery. If any such product proves defective during the application warranty period, Z Technology Inc. at its option, either will repair the defective product without charge for parts and labor or will provide a replacement in exchange for the defective product.

In order to obtain service under this warranty, Customer must notify Z Technology Inc. of the defect before the expiration of the warranty period and make suitable arrangements for the performance of service. Z Technology Inc. will provide such service at its headquarters or at one of its authorized service centers. Customer shall be responsible for all taxes, duties, packaging, shipping and insuring of the defective product to the service center designated by Z Technology Inc. with all these expenses prepaid. Z Technology Inc. shall pay for return shipping to Customer at the same location from which the product was shipped.

This warranty shall not apply to any defect, failure or damage caused by improper use or improper or inadequate maintenance and care. Z Technology Inc. shall not be obligated to furnish service under this warranty a) to repair damage resulting from attempts by personnel other than Z Technology Inc. representatives to install, repair or service the product; or b) to repair damage resulting from improper use or connection to incompatible equipment.

THIS WARRANTY IS GIVEN BY Z TECHNOLOGY INC. IN LIEU OF ANY OTHER WARRANTIES, EXPRESSED OR IMPLIED. Z TECHNOLOGY INC. AND ITS VENDORS DISCLAIM ANY IMPLIED WARRANTIES OF MERCHANTABILITY OR FITNESS FOR A PARTICULAR PURPOSE. Z TECHNOLOGY INC.' RESPONSIBILITY TO REPAIR OR REPLACE A DEFECTIVE PRODUCT IS THE SOLE AND EXCLUSIVE REMEDY PROVIDED TO THE CUSTOMER FOR BREACH OF THE WARRANTY. Z TECHNOLOGY INC. AND ITS VENDORS WILL NOT BE LIABLE FOR ANY INDIRECT, SPECIAL, INCIDENTAL, OR CONSEQUENTIAL DAMAGES, IRRESPECTIVE OF WHETHER Z TECHNOLOGY INC. OR THE VENDOR HAS ADVANCE NOTICE OF THE POSSIBILITY OF SUCH DAMAGES.

Table of Contents

SECTION 1: INTRODUCTION TO THE R-505C	1-1
<i>Two-Way Radio Systems and Paging Systems.....</i>	<i>1-1</i>
<i>Cellular Telephone Systems:</i>	<i>1-1</i>
<i>Broadcast Transmission Testing:.....</i>	<i>1-1</i>
SUMMARY OF FEATURES AND SPECIFICATIONS.....	1-1
SECTION 2: SPECIFICATIONS.....	2-1
<i>R-505C Specifications</i>	<i>2-1</i>
Tuned Frequency	2-1
<i>Resident Data Logging Modes.....</i>	<i>2-2</i>
Options.....	2-3
Standard Accessories.....	2-4
SECTION 3: FIRST TIME OPERATION.....	3-1
SET UP AND PREPARING TO OPERATE.....	3-1
SECTION 4: FRONT PANEL CONTROLS & OPERATION	4-1
<i>Background Information For Basic Operation.....</i>	<i>4-1</i>
<i>Input Impedance.....</i>	<i>4-1</i>
<i>Field Strength versus Signal Strength.....</i>	<i>4-1</i>
<i>In-Band Signal Measurements and Out-of-Band Signal Rejection</i>	<i>4-2</i>
<i>Front Panel Frequency Selection.....</i>	<i>4-3</i>
FRONT PANEL OPERATION.....	4-4
<i>Front Panel Description</i>	<i>4-4</i>
Turning on the Power	4-6
Frequency Setting	4-6
Making a Signal Strength Reading:.....	4-6
Using The RF AMP Control	4-7
WB & NB BANDWIDTH.....	4-8
ADVANCED OPERATION	4-8
FREQ/CH Button.....	4-8
FUNCTION Button.....	4-9
MEMORY Button:.....	4-9
TUNE knob Features.....	4-9
Auto Power-Down Feature.....	4-10
SECTION 5: MEMORY FEATURES.....	5-1
MEMORY FEATURE (MEMORY BUTTON OPERATION).....	5-1
USER MEMORY Storage	5-1
USER MEMORY Retrieval.....	5-2
SECTION 6: FUNCTION FEATURES	6-1
FUNCTION FEATURES (FUNC BUTTON OPERATION)	6-1
Functions.....	6-1
Selecting a Function	6-1
FUNCTION LISTING AND DESCRIPTION	6-2

Table of Contents

F1: BATTERY VOLTAGE CHECK.....	6-3
F3: CUSTOMER CALIBRATION (MINOR).....	6-3
F4: VIEW TV CHANNEL PLAN.....	6-3
F5: DISABLE AUTO-POWER-DOWN.....	6-3
F7: SET SCAN STEP FREQUENCY.....	6-4
F8/F9: SET SCAN START FREQUENCY/SET SCAN STOP FREQUENCY.....	6-4
F10: AUTO-CONTIGUOUS RESIDENT DATA LOGGING.....	6-4
F11: MANUAL CONTIGUOUS RESIDENT DATA LOG.....	6-5
F21: ERASE USER MEMORY (1-10).....	6-6
F28: SOFTWARE VERSION #.....	6-6
F40: (Locked User Functions).....	6-6
F41: (Locked User Function) SELECT CUSTOMER CALIBRATION TABLE.....	6-7
F42: (Locked User Function) SELECT FACTORY CALIBRATION TABLE.....	6-7
F43: (Locked User Function) SET RS-232 BAUD RATE.....	6-7
F44: SET RS-232 REMOTE ADDRESS.....	6-7
F45: (Locked User Function) SET 24-HOUR CLOCK.....	6-7
F46: (Locked User Function) SET MONTH/DAY.....	6-8
F47: (Locked User Function) SET YEAR.....	6-8
F48: CLONE ANOTHER R-505C.....	6-8
F59: UNLOCKS USER FUNCTIONS F40 - F48.....	6-9
F91: RESET DATA RECORD COUNTER.....	6-9
F93: REMOTE MODE.....	6-9
PRINTING RECORDED DATA.....	6-9
F94: PRINT (RS-232) SELECTED DATA LOG RECORD.....	6-10
F95: PRINT (RS-232) ALL DATA LOG RECORDS.....	6-10
F96: AUTO - USER MEMORY RESIDENT DATA LOGGING.....	6-10
F98: MANUAL - USER MEMORY RESIDENT DATA LOGGING.....	6-11
SECTION 7: RESIDENT DATA LOGGING.....	7-1
WHAT IS RESIDENT DATA LOGGING?.....	7-1
COMMON SETUP PARAMETERS.....	7-2
<i>Front Panel Pre-settings</i>	7-2
<i>Description Of CONTIGUOUS RESIDENT DATA LOGGING</i>	7-3
<i>Using F10: AUTOMATIC (timed) CONTIGUOUS RESIDENT DATA LOGGING</i>	7-4
<i>Using F11: MANUAL CONTIGUOUS DATA LOGGING</i>	7-4
DESCRIPTION OF USER MEMORY DATA LOGGING.....	7-8
<i>Using The USER MEMORY RESIDENT DATA LOGGING Functions:</i>	7-8
<i>Using F96: AUTOMATIC (timed) USER MEMORY RESIDENT DATA LOGGING</i>	7-8
<i>Using F98: MANUAL USER MEMORY DATA LOGGING</i>	7-9
SECTION 8: DATA LOGGING APPLICATION GUIDE.....	8-1
INSTALLATION AND SETUP:.....	8-2
<i>Connecting The R-505C to a Printer:</i>	8-2
<i>Connecting the R-505C to a Computer:</i>	8-4
OPERATION:.....	8-5
<i>Sending Records to a Printer:</i>	8-5
<i>Sending Records to a Computer:</i>	8-5
PROBLEMS AND FIXES:.....	8-6
<i>Symptom:</i>	8-6

<i>Symptom:</i>	8-6
<i>Symptom:</i>	8-6
<i>Symptom:</i>	8-7
<i>Symptom:</i>	8-8
RS-232 CABLES AND ADAPTERS	8-9
<i>RS-232 I/O Cable</i>	8-9
<i>RS-232 I/O Cable R-500 Series to PC AT</i>	8-10
<i>RS-232 Adapter</i>	8-10

SECTION 9: SERIAL COMMAND PROTOCOL 9-1

HARDWARE	9-1
SOFTWARE	9-1
COMMANDS	9-2
<i>Command Protocol</i>	9-3
DESCRIPTION.....	9-4
BIT# DESCRIPTION	9-4
<i>COMMAND 1</i>	9-5
<i>COMMAND 2</i>	9-5
<i>COMMAND 3</i>	9-5
<i>COMMAND 4</i>	9-5
<i>COMMAND 5</i>	9-6
<i>COMMAND 6</i>	9-6
<i>COMMAND 7</i>	9-6
<i>COMMAND 8</i>	9-6
<i>COMMAND 9</i>	9-6
<i>COMMAND 10</i>	9-7
<i>COMMAND 11</i>	9-7
<i>COMMAND 12</i>	9-7
<i>COMMAND 13</i>	9-7
<i>COMMAND 14</i>	9-7
<i>COMMAND 15</i>	9-8
<i>COMMAND 16</i>	9-8
<i>COMMAND 17</i>	9-8
<i>COMMAND 18</i>	9-8
<i>COMMAND 19</i>	9-9
<i>COMMAND 20</i>	9-9
<i>COMMAND 23</i>	9-9
<i>COMMAND 24</i>	9-9
<i>COMMAND 25</i>	9-10
<i>COMMAND 26</i>	9-10
<i>COMMAND 27</i>	9-10
<i>COMMAND 28</i>	9-11
<i>COMMAND 29</i>	9-11
<i>COMMAND 30</i>	9-12
<i>COMMAND 31</i>	9-12
<i>COMMAND 32</i>	9-12
<i>COMMAND 33</i>	9-13
<i>COMMAND 34</i>	9-13
<i>COMMAND 35</i>	9-13

Table of Contents

COMMAND 36	9-13
COMMAND 37	9-13
COMMAND 38	9-13
COMMAND 39	9-14
COMMAND 40	9-14
COMMAND 42	9-14
COMMAND 43	9-14
COMMAND 44	9-15
COMMAND 45	9-15
COMMAND 46	9-16
COMMAND 47	9-17
COMMAND 55	9-17
COMMAND 57	9-18
COMMAND 60	9-18
COMMAND 61	9-19
COMMAND 62	9-19
SECTION 10: QUICK REFERENCE CARD.....	10-1
<i>R-505C BASIC OPERATING INSTRUCTIONS.....</i>	<i>10-1</i>
<i>Function Listing and Description</i>	<i>10-2</i>
SECTION 11: BLOCK DIAGRAM	11-1
SECTION 12: REAR PANEL CONNECTORS.....	12-1
SECTION 13: ADDENDUM	13-1

Section 1: Introduction to the R-505C

Congratulations on choosing the R-505C as your **FIELD/SIGNAL STRENGTH METER**. The R-505C incorporates the latest advances in test and measurement technology into one compact package. The unit is a precision measurement instrument that can be carried into the field or used in the laboratory. In either environment the operator can be assured of highly accurate measurement results.

The R-505C many features make it applicable over a wide range of applications.

Two-Way Radio Systems and Paging Systems

The instrument covers virtually all frequencies presently used by private and public radio communication networks and paging systems. For users requiring test and measurement capability at VHF or UHF (and combinations of both VHF & UHF), the R-505C provides full and continuous coverage from 5.0 MHz to 1000 MHz.

Cellular Telephone Systems:

The entire 800 - 900 MHz spectrum is well within the frequency range of the R-505C. RF and IF Filters are especially tailored to address this industry. In addition, a front panel **MEMORY** function allows the operator to quickly tune to any 10 frequencies or TV channels for rapid signal level measurements.

Continuous multi-channel testing is possible using the RS-232 serial port interfaced to a standard IBM compatible PC. This allows creation of applications specific control programs such as ones for generating automated signal coverage contour plots.

Broadcast Transmission Testing:

The unit has several features required by AM, FM and television broadcasters.

A 150 kHz wideband IF filter is available for measuring systems with wide modulation formats.

Simultaneously active AM & FM detectors drive an internal speaker; and allow easy aural program confirmation of the measured signal.

A special TV channel-tuning feature is also provided. Using the **FREQ/CH** button and the main front panel TUNE knob, the operator is able to step from one channel to the next with each detent of the knob.

SUMMARY OF FEATURES AND SPECIFICATIONS

Major features of the R-505C are discussed in detail throughout this manual. A summary of the most critical specifications and features are listed below.

- ◆ FREQUENCY COVERAGE: 5.0 MHz TO 1000MHz

Section 1: Introduction to the R-505C

- ◆ MEASUREMENT RANGE: -10 dBuV TO +90 dBuV
- ◆ ABSOLUTE MEASUREMENT ACCURACY: +/- 2 dB
- ◆ EASY TO USE INTERNAL PREAMPLIFIER
- ◆ USER SELECTABLE **BANDWIDTH**: Narrow = 15 kHz; Wide = 150 kHz
- ◆ FRONT PANEL SELECTABLE INTERNAL AM & FM **AUDIO** DETECTOR WITH SPEAKER
- ◆ FRONT PANEL SELECTABLE AUDIO LEVEL
- ◆ FRONT PANEL **MEMORY** CONTROL FEATURE FOR FAST STORAGE & RECALL
- ◆ FRONT PANEL **FREQUENCY/CHANNEL** MODE FOR USE WITH TELEVISION SIGNALS
- ◆ PC/PRINTER INTERFACE WITH DATA LOGGING
- ◆ BATTERY AND/OR AC LINE OPERATION
- ◆ ADDITIONAL EXTERNAL BATTERY INPUT
- ◆ EASY TO OPERATE FRONT PANEL CONTROLS
- ◆ RUGGED, LIGHT WEIGHT AND HIGHLY PORTABLE

The R-505C provides state-of-the-art precision signal strength testing over a wide range of signal levels. It has extremely broad frequency coverage and provides a measurement accuracy of 2 dB or better. The highly portable unit combines the functions of off-air field strength metering and accurate RF signal strength measurement with data logging/storage and PC control in one convenient lightweight hand-held system.

The standard R-505C will accurately measure signal strength from -10 dBuV (0.32 uVolt) to +90 dBuV (31.6 mvolts). The full dynamic range of 100 dB is available through a combination of user selectable controls and an auto-ranging function. Auto ranging provides a continuous measurement range of 80 dB. With the **RF AMP** (preamplifier) OFF the autorange coverage is +10 dBuV to +90 dBuV. With the **RF AMP** ON, the auto-range is transposed down and becomes -10 dBuV to +70 dBuV. The R-505C remembers the **RF AMP** setting from its previous power down state.

The Preamplifier is protected from overload by a series of three user selectable internal RF Filters which allow measurement of weak signals while protecting against unwanted strong signal overload. These filters in combination with the selectable Narrowband 15 kHz and Wideband 150 kHz IF filters provide effective rejection of adjacent channel and out of band signals while precisely determining signal strength on the desired frequency.

An operator can accurately measure signals at all frequencies from 5.0 to 1000 MHz. The R-505C utilizes a digitally encoded front panel **TUNE** knob for tuning selections. Step sizes of 100, 10, & 1 MHz as well as 100, 10, & 1 kHz are provided with the **TUNE** knob. The entire system is fully synthesized.

The unit offers internal recall of up to 10 user-defined frequencies, which are programmed via the front panel and easily accessed using the **TUNE** knob.

Several television channel assignment plans are included in the instrument for user testing of television transmitters. The **FREQ/CH** front panel button determines if the **TUNE** knob tunes frequency in MHz, or the assigned television channel plan's channels.

The R-505C features simultaneous digital read out of signal strength and frequency being monitored on a single large LCD panel. The display can be backlit for operating in low ambient light.

AM and FM detectors are user selectable by a front panel **AUDIO** button allowing quick aural identification of signals. The instrument includes an internal water-repellent speaker and rear panel headphone jack.

Measured signal levels and associated frequency or channel readings can easily be stored inside the R-505C using the RESIDENT DATA LOGGING feature. A rear panel RS-232 port is provided to download stored information directly to a serial printer or an IBM compatible PC.

The RS-232 port operates at baud rates of 1200, 2400 or 9600 and can be used to access the R-505C for unique user created programs and control.

The product measures 3.5" high x 8.4" wide x 9" deep (89 x 213 x 229mm) and weighs less than 10 lbs (4.5 kgs). Its compact size makes the unit ideal for one-man portable operation in all types of environments and terrain. Several options provide a choice of extra features and appropriate antennas.

The following features are standard for all R-505C models:

- ◆ Internal NICAD battery pack
- ◆ AC power supply and battery charger
- ◆ Water repellent Soft-Case
- ◆ Internal Speaker
- ◆ User Selectable AM & FM Detectors
- ◆ Backlit LCD display
- ◆ TUNE KNOB operation for tuning
- ◆ Wideband frequency coverage
- ◆ Synthesized tuning to 1kHz resolution
- ◆ 100dB dynamic measurement range
- ◆ 10 stored user defined frequency or channel settings
- ◆ Instrument set-ups accessible via Front Panel Function Controls
- ◆ Quick Basic Control Software disk for RS-232 PC Control

The R-505C will operate more than 5 hours on internal NiCad batteries or from an AC power supply/charger system. Battery operation along with the durable carrying case allows operation at even the most remote sites. Additional battery operation life can be achieved via an external battery plugged into the rear panel External Battery input jack. When an external battery is connected the internal battery is disconnected for both meter power, and battery charging. An external battery will be charged when both it and the AC power supply/charger are plugged into the meter.

Section 2: Specifications

<u>R-505C Specifications</u>	
Frequency Range:	5.0 MHz to 1000 MHz
Tune Mode:	Synthesized Steps as small as 1 kHz
Memory:	a) 10 user-stored frequencies or channel settings. Tune Knob-retrievable in sequence. b) Several TV channel plans stored in memory.
Measurement Ranges:	Standard Mode: -10 dBuV to +90 dBuV utilizing autoranging plus front panel controlled gain setting.
Input Filters:	Three automatically selected RF filter bands.
Tuned Frequency	RF Filter
400.001 MHz – 1000 MHz	400 MHz High Pass
30.001 MHz - 400 MHz	400 MHz Low Pass
5.0 MHz - 30 MHz	30 MHz Low Pass
Measurement Resolution:	0.1dB
Measurement Accuracy:	+/-2 dB; for CW signal, Absolute for Temp 15 to 35 Deg. C Typical for Temp 0 to 50 Deg. C
	Note: Some types of modulation influence measurement accuracy. For instance, with Video modulation, the R-505C measures the signal level of the Vertical Sync Peak. This adds 0.5 dB of addition uncertainty, widening the spec to +/- 2.5 dB.
Input Impedance:	50 Ohm
IF Bandwidth:	15 kHz and 150 kHz
Type of Conversion:	Triple conversion system. 1st LO freq 1 to 2 GHz
Ref Osc. Stability:	1st & 2nd LO typ. Stable +/-1ppm over temp.
2nd IF Rejection:	70 dB (2nd IF = 47 MHz)
Image Rejection:	60 dB typ, High Sensitivity Mode.
Audio Detection:	AM and FM with internal monitoring speaker. Rear panel connector for remote speaker or headphone. BW is 300Hz to

Section 2: Specifications

<u>R-505C Specifications</u>	
	3KHz.
Noise Figure:	Preamplifier NF = 7 dB (when RF AMP is selected)
Sensitivity:	1 uV input, AM Detection for 12 dB S/N 1 uV input, FM Detection for 12 dB SINAD
Third Order Intercept:	Pre Amp ON typ. 0 dBm; Pre Amp OFF +20 dBm.
Operating Temperature:	-10 to +50 Deg. C.
Weight:	4.5 Kg (10 lbs)
Dimensions:	89mm(3.5in)High; 229mm(9in)Deep; 213mm(8.4in) Wide

Resident Data Logging Modes

The instrument provides three unique and separate Resident Data Logging methods for collecting and storing signal level & associated frequency information. Resident Data Logging is normally used when operating in a portable or field situation where connection to a PC is not possible. Data records are collected inside the R-505C and stored for later retrieval.

Contiguous Data Logging (used for most application):

Frequency channel spacing: 10 kHz to 500 kHz, front panel selectable

Frequencies stored per record: up to 360

Method of recording Instrument will internally store 20 records for later retrieval.

Normal operation is to transfer data to a PC upon command with terminal emulator software.

Automatic Timed Records: The time interval between Records can be set in 1 minute intervals from 5 minutes up to 24 hours.

Options

OPT 600	Same features as the R-505C except the upper tuning frequency limit is 600 MHz
BN-5:	Extra Battery Pack, NiCaD
PU-1:	Extra Power Supply/Charger, 115VAC Input
PU-2:	Extra Power Supply/Charger, 220VAC Input
AA-1:	Calibrated Tuned Dipole Set (30MHz -1000MHz)
	AA-1/Balun1, 30 to 70 MHz
	AA-1/Balun2, 65 to 180 MHz
	AA-1/Balun3, 170 to 340 MHz
	AA-1/Balun4, 325 to 1000MHz
AA-2:	Active Monopole Antenna System
	Calibrated (100kHz-60MHz)
AA-3:	Biconical Antenna System
	Calibrated (20MHz-330MHz)
AA-4:	Log Periodic Antenna System
	Calibrated (290MHz-1000MHz)
AA-6:	Log Periodic Antenna System
	Calibrated (150MHz-1000MHz)
AA-7:	Bi-Log Periodic Antenna System
	Calibrated (25MHz - 1000MHz)
AA-8:	Log Periodic Antenna System
	Calibrated (800MHz - 2600MHz)
TSC-2542:	Antenna Carrying Case
ATU-251:	Tripod; Non Conductive Design
AEH-251:	Azimuth/Elevation Head for Tripod
TCC-251:	Tripod Carrying Case
CAB211/301:	3 Meter RG-214U Cable; with N/N Plugs

Section 2: Specifications

Standard Accessories

Carrying case with shoulder strap

Rechargeable NiCAD Battery Pack (located inside instrument when shipped)

Collapsible vertical utility antenna

Type-N male to BNC female adapter

115 VAC or 220VAC Power Source & Battery Charger (dependent on shipment destination)

Operators manual

Quick Reference Operators Card

RS232C Comm. Port

RS-232 I/O Cable

Quick Basic Control Software diskette 3.5"

R-500 Series Application Notes

Section 3: First time Operation

SET UP AND PREPARING TO OPERATE

If you have already unpacked the R-505C and have located the accessories, the following items should be found in every shipment of a standard instrument:

- The R-505C Instrument
- Battery Charger/AC Power Supply
- Type-N Male to BNC Female Adapter
- Collapsible Vertical Utility Antenna
- Soft Carrying Case
- Quick Reference Operators Card
- User Manual
- (NiCad Battery pack is inside the R-505C & not visible)
- RS-232 cable
- Quick Basic Control Software diskette 3.5"
- R-505C Application Notes

Make sure the Battery Charger/AC Power Supply received is appropriate for the AC voltage supplied by your power utility service. Each charger is plainly marked as to the Primary or Input AC voltage expected.

Every R-505C is shipped with a NiCad battery pack already installed inside the instrument. This battery pack is shipped from the factory fully charged and can operate the product for at least 5 hours between recharges. A full recharge will require a 10 to 12 hour connection to the battery charger. During shipment the NiCad pack may have lost some of its charge and should be completely recharged before the instrument is put into full service.

Each Field Strength Meter is shipped inside its soft carrying case. The instrument can be operated while inside this case. (Of course, the unit will operate equally well outside the soft case). Both front and rear panels can be directly accessed through the soft case via Velcro sealed flaps covering the front and rear.

Open the rear flap and notice four connectors: From left to right looking at the rear panel (1) PORT1 - the RS-232 serial port), (2) EXT. BATT. INPUT - the external battery input connector, (3) ACCESSORIES - the round Mini-Din accessories connector, and (4) POWER INPUT - the Batter Charger/AC Power Supply input connector. Finally notice a small hole next to PORT1 labeled SYSTEM RESET. Inserting a pointed object into this hole while the Battery Charger/AC Power Supply is disconnected will reset the meter's internal microprocessor.

Plug the Battery Charger/AC Power Supply into the POWER INPUT connector and allow the internal battery pack to charge for 10 hours.

The Battery Charger/AC Power Supply has enough capacity to recharge the internal battery and at the same time allow full operation of the R-505C.

Section 3: First time Operation

Prepare for operating the unit by opening the Velcro front flap of the soft case and attaching a coaxial cable with the signals to be measured or if desired attach the supplied Collapsible Vertical Utility Antenna to the input connector using the N to BNC adapter.

Now you are ready to operate the Field Strength Meter and should review the next section of this manual entitled "FRONT PANEL CONTROLS AND OPERATING INSTRUCTIONS."

Section 4: Front Panel Controls & Operation

Note: During normal operation, the meter's front Liquid Crystal Display (LCD) shows three lines of information. The Top line is called the **SIGNAL LEVEL** readout, the middle line is called the **FREQUENCY/CHANNEL** readout, and the third line is called the **STATUS** readout.

In this manual, words that describe front panel buttons, or knobs are written in **BOLD CAPS**. Words that callout one of the three readouts are written in **BOLD ITALIC CAPS**. Words letters or numbers that are shown in the readouts are written in BOLD within quotes, example "**F1**".

Background Information For Basic Operation

The R-505C combines wide frequency coverage, a large dynamic range and the excellent measurement accuracy all in one instrument. It is a versatile and rugged unit while also being a precision piece of measurement equipment. As with all precision equipment, the meter must be operated correctly to obtain proper results.

When using this unit, the operator should be aware of the following background information.

Input Impedance

The R-505C has an input impedance of 50 Ohms. In order to make accurate readings, it must be operated in a 50 Ohm environment. That is, the operator should use a 50 Ohm antenna or drive the meter from a 50 Ohm signal source.

Field Strength versus Signal Strength

The R-505C Field Strength Meter is designed to accurately measure the strength of a signal which is presented to the meter at its front panel input connector. The strength of the signal is displayed in large characters in the **SIGNAL LEVEL** readout on the meters front panel. The units attached to this reading will be dBuV. The user may or may not be familiar with this unit of power measurement. A power level of 0 dBuV is equal to 1 uvolt across a 50-Ohm load.

The meter can be used to obtain accurate field strength readings in microvolts per meter (uV/M) when it is used with a calibrated antenna system such as one of the optional antenna systems provided by Z Technology, Inc. See the section of this manual on "Specification, Options and Accessories". To convert from dBuV/M to uV/M use the following formula

$$\text{uV/M} = \text{antilog} (\text{dBuV/M} / 20)$$

Calibrated antenna systems are provided with Calibration Tables listing correction factor data versus frequency for each antenna. The data is taken during individual tests made on an actual antenna test site. This data can be used to add or subtract from the meter reading to determine field intensity in dBuV/M. It is then possible to apply the formula above to produce uV/M. For more information on calibrated antennas see the manuals provided with our calibrated antenna systems, AA-1, AA-2, AA-3, AA-4, AA-5, AA-6, AA-7, and AA-8. If the meter is always used to measure field strength at a single frequency, and other possibility exists, a single point

Section 4: Front Panel Controls & Operation

calibration using the customer calibration function (see the F3 description in the Function Features section later in this manual.)

In-Band Signal Measurements and Out-of-Band Signal Rejection

It is helpful for the operator to be aware of the basic block diagram of any field strength instrument. See the "Block Diagram" section of the manual. Part of this diagram is reproduced below.

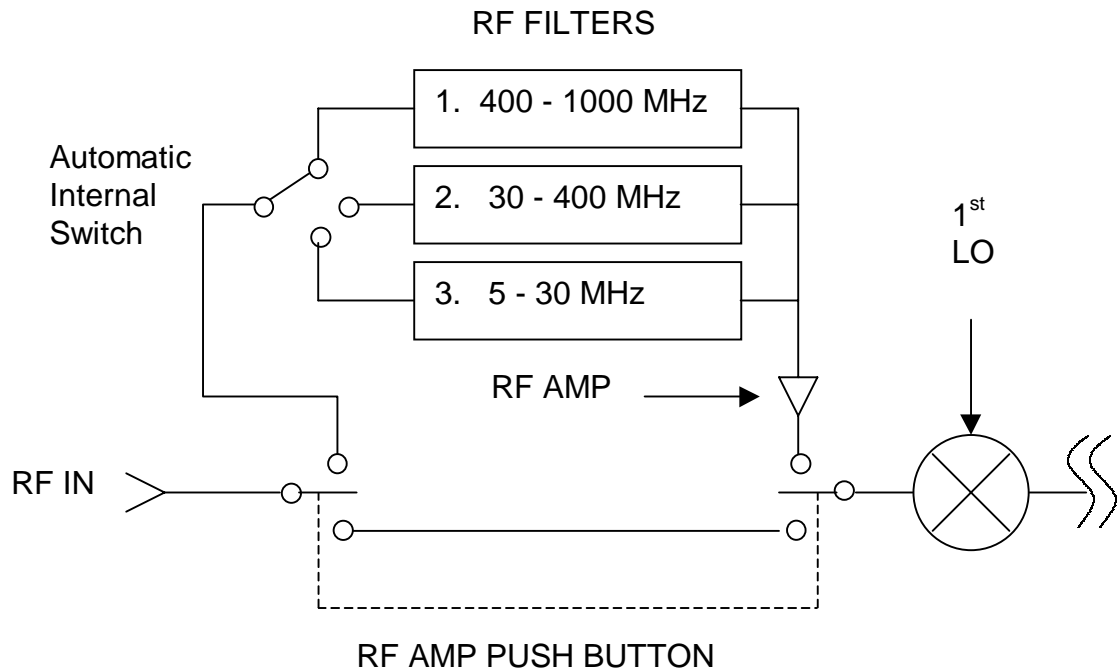

Notice that the instrument is designed with an internal Preamplifier (called the **RF AMP**). When in use, this amplifier gives the meter its excellent small signal measurement capability. The operator can choose when to engage the **RF AMP** through a front panel button control. As can be seen in the diagram, when the **RF AMP** is active one of three frequency dependent **RF FILTERS** are also active. The filters automatically switch depending on what frequency is being tuned. (When the **RF AMP** is turned off both the **RF AMP** and all **RF FILTERS** are bypassed and are not active in the system).

The preamplifier is designed to simultaneously handle both very weak and very strong signals. The **RF FILTERS** are included in the system to improve immunity to interference. See the Specifications section of this manual for frequency covered by each filter. Even with these protections, at times there may be the potential of overloading the Preamplifier (**RF AMP**). The operator can avoid this by following a few simple guidelines.

Preamplifier overload may occur when the **RF AMP** is being used and a very strong undesired signal is within the **RF FILTER** bandpass. It is generally a good idea to start a measurement routine with **RF AMP** turned off. If the measurement can be made without this Amplifier

Section 4: Front Panel Controls & Operation

selected, do so. Use the **RF AMP** feature only when needed to measure weak signals that cannot be captured otherwise.

Front Panel Frequency Selection

The R-505C has a wide frequency coverage range. A single **TUNE** knob provides for frequency selection. The unit is fully synthesized and crystal controlled with minimum step size of 1 kHz. Since the narrowest bandwidth IF Filter is nominally 15 kHz and the smallest synthesized step size is 1 kHz, it requires approximately seven (15) steps to tune across a CW (clear wave) signal at any one frequency. The single **TUNE** knob operation insures it a simple process to make measurements at virtually all frequencies from 5.0 MHz to 1000 MHz.

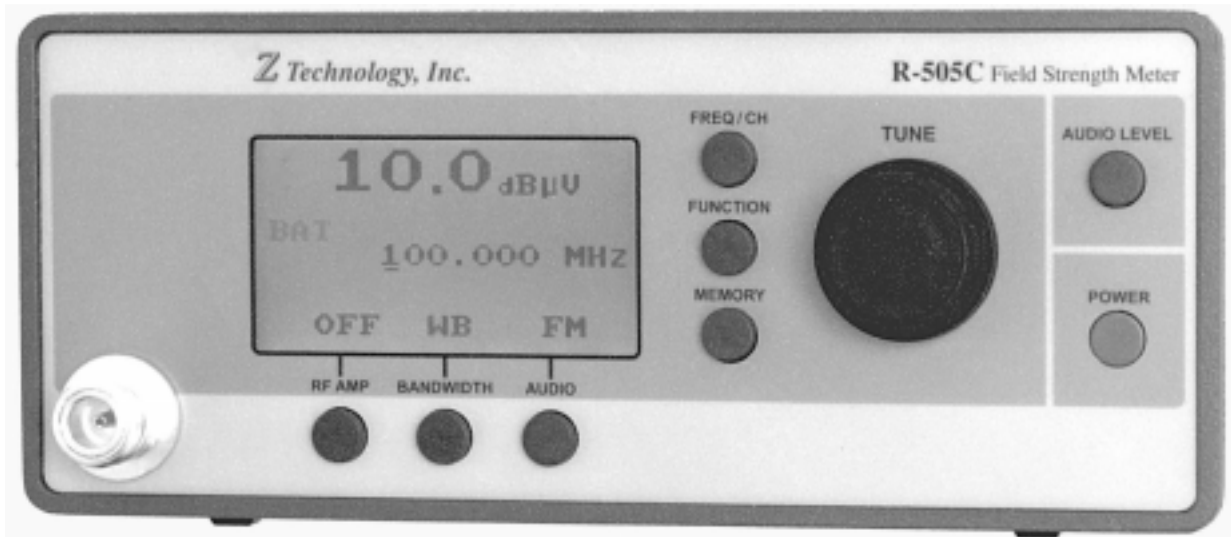

**R-505C Field Strength Meter
Front Panel**

FRONT PANEL OPERATION

Front panel operation for the R-505C can be best described by referring to the accompanying product picture or by directly operating the controls of the Field Strength Meter.

First, we will describe the basic operation of the main front panel controls. Later, in-depth information concerning additional controls and useful complimentary features will be discussed.

Note: During normal operation, the meter's front Liquid Crystal Display (LCD) shows three lines of information. The Top line is called the **SIGNAL LEVEL** readout, the middle line is called the **FREQUENCY/CHANNEL** readout, and the third line is called the **STATUS** readout.

In this manual, words that describe front panel buttons, or knobs are written in **BOLD CAPS**. Words that callout one of the three readouts are written in **BOLD ITALIC CAPS**. Words letters or numbers that are shown in the readouts are written in BOLD within quotes, example "**F1**".

Front Panel Description

The instrument's front panel inputs and controls include:

- 50 Ohm Type-N RF input connector
- LCD display area, becomes active when meter turned on
- 8 Grey push buttons, 3 located horizontally below the display, 3 located vertically to the right of the display, 2 located vertically at the right side. They are labeled:

RF AMP
BANDWIDTH
AUDIO

FREQ/CH
FUNCTION
MEMORY

AUDIO LEVEL
POWER

- Frequency set up and control **TUNE** knob

The 50 ohm Type-N RF input connector is to be connected to an antenna cable directly or via the Type-N to BNC adapter supplied with the meter.

The LCD display area becomes active when the unit is powered on. It allows the user to interact with the meter. There are three distinct readout areas on LCD. The top line with the largest characters is the **SIGNAL LEVEL** readout, next in the middle is the **FREQUENCY/CHANNEL** readout, at the bottom is the **STATUS** readout. Information is presented in these three readout areas as shown below.

Section 4: Front Panel Controls & Operation

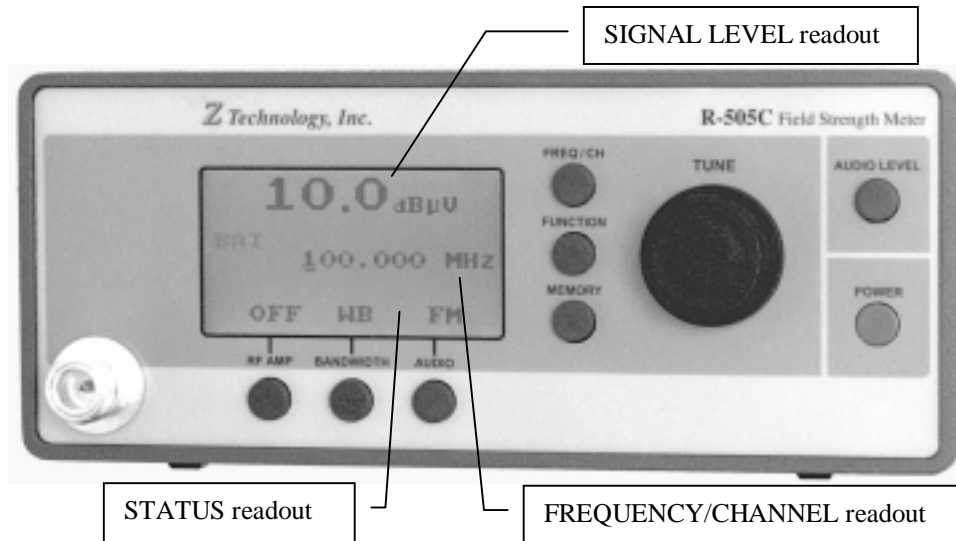

The **RFAMP** button turns on and off the RF amplifier. The **STATUS** readout above the button reads "ON" or "OFF" respectively.

The **BANDWIDTH** button switches the internal IF Filter between 15KHz Filter (Narrow Band) and 150KHz Filter (Wide Band). The **STATUS** readout above the button reads "NB" or "WB" respectively.

The **AUDIO** button switches between the internal AM and FM decoders. The **STATUS** readout reads "AM" or "FM" respectively.

The **FREQ/CH** button switches between Frequency tuning mode, and TV channel tuning mode. The above illustration shows the meter in frequency tuning mode. The **FREQUENCY/CHANNEL** readout shows the tuned frequency followed by "MHz". When in TV channel tuning mode the **FREQUENCY/CHANNEL** readout shows the tuned channel number followed by "P" for picture, or "A" for audio.

The **MEMORY** button toggles the meter in and out of Memory tuning mode. When in Memory tuning mode the numonic "MEM" is shown in the left side of the **FREQUENCY/CHANNEL** readout. See the Memory Feature section later in this manual for further explanation.

The **AUDIO LEVEL** button controls the audio level of the internal speaker as well as the speaker pins on the rear panel accessory connector. Pressing the Audio Level button and holding it, increases the audio level to full volume in about 10 seconds. Continuing to hold the button down will decrease the audio level to minimum volume in about another 10 seconds. Releasing the button, then pushing it again reverses the direction of change.

The **POWER** button turns the meter on and off. The backlight automatically comes on and stays on if the meter is connected to its AC supply/charger. If the meter is running off battery power, the backlight will automatically turn off a few seconds after power on. Once the meter is on and the readouts have stabilized pressing the **POWER** button down and holding it until the

Section 4: Front Panel Controls & Operation

unit beeps, (about 2 seconds) turns toggles the LCD backlight. When the meter is on, a quick press and release of the **POWER** button turns the unit off.

The **TUNE** knob is a multi-function control. It both rotates, and depresses. Rotating it generally changes the values in the **FREQUENCY/CHANNEL** readout. Pressing it generally activates a selected function. (See Function Features section later in this manual.)

The following procedure is the normal measurement sequence.

Turning on the Power

Push the power button (**POWER**) to turn ON the instrument. If the AC supply/charger is connected to the rear panel the unit will be powered from that supply. When the AC supply/charger is not connected the instrument automatically switches to the internal NiCad battery pack. If an external battery is connected via the rear panel EXT. BATT. INPUT the instrument uses the external battery for power, and disconnects the internal battery.

Frequency Setting

The primary frequency selection control is the **TUNE** knob. It controls the frequency or channel number shown in the **FREQUENCY/CHANNEL** readout. Turn this knob and notice the detent action of the knob. Each detent will change the frequency or channel by one unit. (The **TUNE** knob has many other uses -- we will describe them throughout this manual).

Push and release this knob to change the step size of each detent position. By pushing the knob and hearing an accompanying audible beep, the step size changes to: 100 MHz, 10 MHz, 1 MHz, 100 kHz, 10 kHz or 1 kHz. An underline indicates the chosen step size.

Making a Signal Strength Reading:

In many applications the next and final step is to read the Signal Level in dBuV from the **SIGNAL LEVEL** readout.

The accompanying Signal Level Conversion Table is provided to show the relationship between signal level at the front panel connector in the units of Volts, dBuV, or dBm. Remember, this is valid for a 50 ohm system. (Note: to convert from dBuV to dBm subtract 107dB.)

SIGNAL LEVEL CONVERSION TABLE			
SIGNAL LEVELS AT RF INPUT CONNECTOR			Front Panel Selections
Vin @ 50ohms	dBuV	dBm	
0.32uV	-10 dBuV	-117 dBm	RF AMP "ON"
0.5uV	-6 dBuV	-113 dBm	RF AMP "ON"

Section 4: Front Panel Controls & Operation

SIGNAL LEVEL CONVERSION TABLE			
SIGNAL LEVELS AT RF INPUT CONNECTOR			Front Panel Selections
Vin @ 50ohms	dBuV	dBm	
1.0uV	0 dBuV	-107 dBm	RF AMP "ON"
3.16 uV	10 dBuV	-97 dBm	
100 uV	40 dBuV	-67 dBm	
7.07mV	77 dBuV	-30 dBm	
31.6mV	90 dBuV	-17 dBm	

When the **SIGNAL LEVEL** readout shows either a blinking ">" or "<" sign the signal presented to the meter at the received frequency is out of measurement range. If this is the case, continue with the procedures below.

Using The RF AMP Control

NOTE: Upon power on the R-505C remembers its settings from the previous power down for the **RF AMP**, **IF AMP**, **FREQ/CH**, and **MEMORY** buttons. It also remembers the tuned frequency or channel. The **AUDIO** button, and **AUDIO LEVEL** buttons default to **"FM"** and 1/4 volume respectively with each power on. The meter is typically shipped with **RF AMP** set to **"OFF"**, **BANDWIDTH** set to **"WB"**, tuned to 100 MHz in frequency tuning mode (i.e. not TV channel or memory tuning mode)

With the typical factory default settings, the instrument has a continuous measurement range from 10 dBuV to 90 dBuV. The unit will always have an auto-range control span of 80 dB. As will be seen, this range can be shifted down to lower power levels.

If the signal to be measured is larger than 90 dBuV (31.6mV) the **SIGNAL LEVEL** readout will display **> 90.0 dBuV** with the ">" sign blinking. In this case, an external attenuator must be used for the unit to measure the level of the signal.

If the signal to be measured is smaller than 10 dBuV (3.16uV) the **SIGNAL LEVEL** readout will display **< 10.0 dBuV** and the "<" sign will be blinking. In this case, the operator must utilize **RFAMP** front panel amplifier control to bring the signal within the range of the meter.

When the **RF AMP** is active, the measurement range of the R-505C extends down to -10 dBuV or 0.32 uVolts. The autorange span with the **RF AMP** active is from -10 dBuV to +70 dBuV.

For all these settings, when a signal is out of range, the "<" Less Than or ">" Greater Than sign will flash. When a signal is properly within autorange levels and a stable number in the **SIGNAL LEVEL** readout is achieved, the user has a valid Signal Level Measurement.

Section 4: Front Panel Controls & Operation

At signal levels close to 0.32 uvolts where noise floors can effect reading, it is best to make measurements with the **BANDWIDTH** button set to "**NB**". See the next section for details.

WB & NB BANDWIDTH

There are two IF Filter bandwidths selectable by the front panel **BANDWIDTH** button.

"**WB**" or Wideband filter of 150 kHz

"**NB**" or Narrowband filter of 15 kHz

The typical Factory Shipped default is "**WB**". The meter remembers whatever setting was active at the last power down and uses that at the next power up.

The wideband filter normally used when looking for a desired signal whose specific frequency is not known. It also should be used when measuring signals which are being deviated with wideband modulation. In such cases peak deviations may disperse energy outside the bandpass of the 15 kHz narrowband filter.

NOTE: The wideband "**WB**" filter is broad enough to cover more than each 100 kHz step of the **TUNE** knob. Thus by using the **TUNE** knob to step in 100 kHz steps, an operator can be confident he has continuously covered all the spectrum as he turns the **TUNE** knob to explore a specific band of frequencies. This feature is useful when attempting to locate a signal whose exact frequency is not known.

When a signal frequency is precisely known the user may select the narrowband "**NB**" filter. This will reduce out of band noise and reject adjacent signals.

Advanced Operation

FREQ/CH Button

(For Fast Television Channel Selection)

The R-505C will easily tune normal television channels. The unit can be incremented by channel number or in units of frequency.

The **FREQUENCY/CHANNEL** readout is designed to toggle between FREQUENCY and CHANNEL modes by pressing the **FREQ/CH** button.

When the **CH**annel mode is chosen each detent of the **TUNE** knob will move the received frequency by one channel usually 6, 7 or 8 MHz depending on the television channel plan in use. See F4 of the Function Features section later in this manual for descriptions to view factory selected channel plan.

Upon pushing the **FREQ/CH** button, the **FREQUENCY/CHANNEL** readout will display the Channel number being received. Either a "**P**" for picture "**P**" or an "**A**" for Audio will be displayed by the LCD readout. Changing between picture or audio reception is accomplished by pushing the **TUNE** knob. To see what frequency a particular TV channel Picture or Audio

Section 4: Front Panel Controls & Operation

carrier is. Tune to that channel, select Picture or Audio, then press the **FREQ/CH** button. The frequency will appear followed by "**MHz**" in the **FREQUENCY/CHANNEL** readout.

FUNCTION Button

(For Set-up and Data Logging Access)

The **FUNCTION** button gives access to a wide range of set-up and data logging/communications functions. Set up operations and certain operating features are accessible as **FUNCTIONS**. Press the **FUNCTION** button then turn the **TUNE** knob to sequentially call control options.

Example information available through the **FUNCTION** button:

F 1: When the **FUNCTION** button is first pushed, the **FREQUENCY/CHANNEL** readout will display "**F1**". Now push the **TUNE** knob. The **FREQUENCY/CHANNEL** readout changes to show the voltage across the internal NiCad battery pack. When the **FUNCTION** button is pushed again, the R-505C will go back to normal operating Field Strength Meter (FSM) mode.

F 5: Push the **FUNCTION** button to display "**F1**". Turn the **TUNE** knob until the **FREQUENCY/CHANNEL** readout displays "**F5**". This function allows the user to select auto power-down mode. Push the **TUNE** knob and notice the display reads either "**AUTO**" or "**ON**". In "**AUTO**" mode the instrument will automatically turn itself OFF when operating from the internal battery pack after 5 minutes of no front panel activity. In "**ON**" mode the unit will stay ON until manually turned off or until the battery voltage reaches a low enough voltage for the meter to cycle itself off. Choose either "**AUTO**" or "**ON**" by turning the **TUNE** knob. To activate your choice, push the **FUNCTION** button and notice that the unit reverts to normal operating Field Strength Meter (FSM) mode.

See the section entitled "FUNCTION FEATURES" for a complete discussion of the wide range of useful features available through this function.

MEMORY Button:

(A Quick way to Store and Recall often used frequencies)

The **MEMORY** button allows storage and retrieval of up to 10 user defined frequency or channel settings in **USER MEMORY**. This is a very useful feature when the operator is continually monitoring a few frequencies or channels which may be spread over many megahertz. See the Section titled **MEMORY OPERATIONS** for programming information. When the memory is programmed, each detent of the **TUNE** knob moves the received frequency to the next memorized frequency or channel. Up to 10 different frequencies or channels can be stored in **USER MEMORY**. It uses a wrap-around feature where the first **USER MEMORY** position follows the last programmed frequency or channel i.e. 1,2,3,..9,10,1,2.

TUNE knob Features

(Addition Uses)

Section 4: Front Panel Controls & Operation

The **TUNE** knob is used to set the R-505C to a desired frequency (or television channel); to select USER MEMORY locations for frequency or channel storage and retrieval, and to control various set up and data collection features.

The **TUNE** knob also contains a switch. This switch is operated when the **TUNE** knob is pushed toward the front panel. Some uses of this extra feature within the **TUNE** knob are detailed here while other uses are discussed in the appropriate places throughout this manual.

A summary of functions controlled by the **TUNE** knob follows:

Frequency Selection:	Turn and/or push to make selections.
Television Channel Selection:	Used with FREQ/CH Button.
Recall USER MEMORY Frequency or Channel Settings:	Used with MEMORY Button.
Program Selection Control:	Used with FUNCTION Button.

Auto Power-Down Feature

If the R-505C is operating from the battery it will automatically power-down if there has been no operator front panel activity for at least five (5) minutes. This feature can be temporarily disabled using function F5. See the above example or the section titled FUNCTION FEATURES for more information.

The unit will also automatically power-down if the charge in the battery pack drops below a usable level. As the voltage of the battery pack (an 8 cell, series NiCad pack) approaches that level, a Low Battery indicator "**BATT**" just below the **SIGNAL LEVEL** readout will begin to blink slowly. As the voltage continues to drop, the "**BATT**" indicator blinks faster. When the voltage decreases below a usable level, the unit automatically powers-down. (The R-505C will display the battery voltage on command. Use F1: Battery Mode and see the FUNCTION FEATURES section for more details.)

Section 5: Memory Features

MEMORY FEATURE (MEMORY BUTTON OPERATION)

As an alternative to sequentially tuning through the frequency spectrum, or a pre-programmed Channel Plan (see F4 - View TV Channel Plan.) The operator can tune through a series of frequencies or channels stored in memory.

USER MEMORY Storage

There are ten (10) USER MEMORY locations available. Any of the ten locations (1-10) may be programmed with the current meter frequency or channel setting. The procedure for programming a memory location is as follows:

1. Tune the R-505C to the frequency or channel (including picture or audio) to be stored.
2. Enter the **FUNCTION** mode by the NORMAL operation of the **FUNCTION** button.
3. Enter the MEMORY-PROGRAMMING mode by the NORMAL operation of the **MEMORY** button. A "**P1 xxx.xxx MHz**" appears in the **FREQUENCY/CHANNEL** readout. The P1 indicates that the first (#1) memory location is currently selected to be programmed. xxx.xxx is the frequency of the previously recorded location.
4. Rotate the **TUNE** knob until the desired USER MEMORY location (1-10) is shown in the **FREQUENCY/CHANNEL** readout. If this USER MEMORY location has already been programmed, its stored setting will be displayed in the **FREQUENCY/CHANNEL** readout. Storing a new setting overwrites the previous setting.

NOTE: USER MEMORY locations must be programmed in sequence. The R-505C will not allow USER MEMORY locations to be skipped, but not all USER MEMORY locations need be programmed. When retrieving frequency or channel settings, the R-505C will access only the locations that contain valid programmed settings.

5. Store the current frequency or channel setting in the selected memory location by the NORMAL operation of the **TUNE** knob. After the TUNE knob is pressed the xxx.xxx is updated to show the currently programmed frequency.
6. Exit the MEMORY-PROGRAMMING mode by the NORMAL operation of the **FUNCTION** Button.

NOTE:

- ◆ All one hundred USER MEMORY locations may be erased at once by invoking the F21 function (See the "Functions" Sections for details.)
- ◆ The **RF AMP**, **BANDWIDTH**, and **AUDIO** button states, are not stored.
- ◆ When Memory location 100 is programmed the **FREQUENCY/CHANNEL** readout displays "**P00 xxx.xxxx MHz**"

USER MEMORY Retrieval

The procedure to recall a frequency or channel stored in a USER MEMORY location is as follows:

1. Enter the MEMORY-SELECT mode by the NORMAL operation of the **MEMORY** button. Upon entering this mode, the R-505C is immediately set to the frequency or channel setting stored in the first (#1) USER MEMORY location. The setting is also shown in the **FREQUENCY/CHANNEL** readout.
2. Each clockwise rotary click of the **TUNE** knob selects (recalls from non-volatile memory) the next sequential stored frequency or channel setting.
3. If the recalled setting specifies CHANNEL mode, the R-505C is set to that mode and tuned to the specified picture or audio carrier. If the setting specifies FREQUENCY mode, the R-505C is set to that mode and tuned to the required frequency.
4. If the data retrieved from a USER MEMORY location is invalid (for example, if corrupted by a hardware failure,) the loud speaker outputs three (3) short beeps and the R-505C returns to its previous operating mode.
5. Rotate the **TUNE** knob clockwise to increment the USER MEMORY location selected with wrap-around from high to low. Turn the **TUNE** knob counter-clockwise to decrement the USER MEMORY selection with wrap-around from low to high.

NOTE: Un-programmed USER MEMORY locations can not be retrieved. For example, if only four (4) USER MEMORY locations contain programmed information, the R-505C will sequence 1, 2, 3, 4, 1. This prevents the selection of an un-programmed USER MEMORY location.

6. Exit the **MEMORY-SELECT** mode by the NORMAL operation of the **MEMORY** button. This will restore the R-505C to its previous operating mode.
7. If the R-505C is powered-down while in the MEMORY-SELECT mode, the next power-up of the meter will restore the meter to this mode.

Section 6: Function Features

FUNCTION FEATURES (FUNC BUTTON OPERATION)

Functions

All instrument set-up operations and certain operating features are accessible as FUNCTIONS. All internal data logging and retrieval modes are also accessed as functions.

On the next page is a summary of the functions that were available at the time this manual was shipped. Full descriptions of these functions are provided later in this chapter.

NOTE: Some R-505C controls have both a NORMAL and a HOLD mode of operation. NORMAL mode is activated when these controls are pushed and released within a 2 second period of time. The HOLD mode is activated by pushing and holding the control in for at least 2 seconds.

Selecting a Function

Select any of the front panel accessible FUNCTIONS by using the following procedure.

1. Enter the FUNCTION mode by the NORMAL operation of the **FUNCTION** button. "F1" is always displayed upon entering the FUNCTION mode.
2. Rotate the **TUNE** knob (either clockwise or counter-clockwise) until the desired function number is displayed in the **FREQUENCY/CHANNEL** readout.

NOTE: Functions F40 through F48 are normally locked-out to prevent accidental changes to certain critical parameters. The user can unlock these functions by selecting F59 three times in a row. The functions are re-locked when the R-505C is switched off.

3. Select the displayed FUNCTION by the NORMAL operation of the **TUNE** knob switch. (Press the **TUNE** knob toward the front panel, briefly.)
4. The FUNCTION mode may be exited, before selecting a function, by the NORMAL operation of the **FUNCTION** button.
5. If, while executing any function the operator decides to cancel the operation, he may do so by powering-down the meter, using the NORMAL operation of the **POWER** button.

Section 6: Function Features

Function Listing and Description

F1	BATTERY VOLTAGE CHECK	
F3	CUSTOMER CALIBRATION (MINOR)	
F4	VIEW TV CHANNEL PLAN	
F5	DISABLE AUTO POWER DOWN	
F7	SET SCAN STEP FREQUENCY	
F8	SET SCAN START FREQUENCY	(Frequently accessed functions)
F9	SET SCAN STOP FREQUENCY	
F10	AUTO - CONTIGUOUS RESIDENT DATA LOGGING	
F11	MANUAL - CONTIGUOUS RESIDENT DATA LOGGING	
F 15	SELECT ATTENUATOR SETTING	
<hr/>		
F21	ERASE USER MEMORY (1 - 10)	
<hr/>		
F28	SOFTWARE VERSION #	
<hr/>		
F40	CUSTOMER CALIBRATION (MAJOR)	
F41	SELECT CUSTOMER CALIBRATION	
F42	SELECT FACTORY CALIBRATION	
F43	SET RS-232 BAUD RATE	
F44	SET RS-232 REMOTE ADDRESS	(Locked out User Functions)
F45	SET 24 HOUR CLOCK	{Except F44}
F46	SET MONTH/DAY	
F47	SET YEAR	
F48	CLONE ANOTHER R-505C	
<hr/>		
F59	UNLOCK USER FUNCTIONS F40 - F48	
<hr/>		
F60		(Manufacturer only Functions)
.		{Specially locked out}
.		
F89		
<hr/>		
F91	RESET DATA LOG RECORD COUNTER TO 1	
F93	REMOTE MODE	
F94	PRINT (RS-232) SELECTED DATA LOG RECORD	
F95	PRINT (RS-232) ALL DATA LOG RECORDS	
F96	AUTO - USER MEMORY RESIDENT DATA LOGGING	(Data Logging Functions)
F98	MANUAL - USER MEMORY RESIDENT DATA LOGGING	

F1: BATTERY VOLTAGE CHECK

The charge level of the R-505Cs internal battery may be checked by selecting the F1 function (i.e. pushing the **TUNE** knob). In this function, the battery voltage is displayed in the **FREQUENCY/CHANNEL** readout (Example: "9.68" indicates 9.68 Volts). A fully charged battery pack will have a voltage of 10 volts or more.

F3: CUSTOMER CALIBRATION (MINOR)

The F3 Function enables the user to perform a single-point calibration, using a single frequency calibration source. The following procedure creates a calibration offset (maximum of +/-20.0 dBuV) that will be applied to every signal level measurement.

1. Connect the calibration signal source to the R-505Cs front panel jack. Set the source to the desired frequency.
2. Set the R-505C to the frequency of the calibration source, then enter the F3 function. The R-505Cs reading of source's signal level will be displayed in the **SIGNAL LEVEL** readout.
3. Rotating the **TUNE** knob will increment/decrement the reading in 0.1 dBuV steps. When the **SIGNAL LEVEL** readout displays the true level of the calibration signal, use the NORMAL operation of the **FUNCTION** button to store the displayed offset in non-volatile memory and exit this mode.
4. To set the single-point calibration offset to zero, enter the F3 mode and immediately exit by the NORMAL operation of the **FUNCTION** button without rotation the **TUNE** knob.

F4: VIEW TV CHANNEL PLAN

When this mode is selected, the **FREQUENCY/CHANNEL** readout displays the currently active factory selected channel plan. "AIR", "UHF", or "PAL-D" is displayed. The following table is used at the factory to determine the setting based on the unit's destination.

<u>Shipped to</u>	<u>TV Standard</u>	<u>Setting</u>
North America	NTSC	"AIR"
Europe	PAL	"UHF"
ASIA	PAL-D	"PAL-D"

NOTE: The R-505C TV CHANNEL PLAN is set at the factory. To change the TV CHANNEL PLAN call your Service Center for instructions.

F5: DISABLE AUTO-POWER-DOWN

After selecting the F5 function, rotating the **TUNE** knob will toggle the **FREQUENCY/CHANNEL** readout between "AUTO" and "ON". The NORMAL operation of the **FUNCTION** button while "ON" is displayed, disables the timed auto-power-down feature. It will not affect the auto-power-down under low battery condition.

Section 6: Function Features

After executing F5, the R-505C returns automatically to its previous operating mode.

NOTE: Auto-power-down is enabled each time the meter is powered up.

F7: SET SCAN STEP FREQUENCY

This function allows the operator to select the size of the step frequency to be used by functions F10 and F11.

Upon selecting this function, the **FREQUENCY/CHANNEL** readout will display "000 STEP". The rotation of the **TUNE** knob will increment/decrement the step size in 10kHz steps with wrap around from 10 to 500 and 500 to 10.

Pressing the **FUNCTION** button exits the F7 function and stores the SCAN STEP FREQUENCY in non-volatile memory to be restored each time the meter is powered up.

F8/F9: SET SCAN START FREQUENCY/SET SCAN STOP FREQUENCY

If function F8 is selected, the 6-digit SCAN START FREQUENCY (in MHz) will be displayed in the **FREQUENCY/CHANNEL** readout. Use the **TUNE** knob to select the desired SCAN START FREQUENCY.

If function F9 is selected, the 6-digit SCAN STOP FREQUENCY (in MHz) will be displayed in the **FREQUENCY/CHANNEL** readout. Use the **TUNE** knob to select the desired SCAN STOP FREQUENCY.

Pressing the **FUNCTION** button exits the F7 function and stores the SCAN STEP FREQUENCY in non-volatile memory to be restored each time the meter is powered up.

These frequency settings determine the beginning and ending points for the F10 and F11 functions. They are stored in non-volatile memory and restored each time the meter is powered up.

F10: AUTO-CONTIGUOUS RESIDENT DATA LOGGING

NOTE: To use a RESIDENT DATA LOGGING Feature, it must first be activated through the RS-232 port. This is done by using the "Quick Basic Control Software" disk provided with each R-505C. The activation procedure is described in detail by the application note titled: R-500 Series Quick Basic Control Software. See the description concerning the program MENU.EXE and Setup Address 1888.

Initially, this function displays "LOG :05" in the **FREQUENCY/CHANNEL** readout. The ":05" indicates the minimum interval of 5 minutes. The rotation of the **TUNE** knob increments/decrements the interval in 1 minute steps. The maximum interval is 24 hours "24:00". Note the display increments from ":59" (59 Minutes) to "1:00" (1 hour, 00 minutes)

Up to twenty (20) measurement records can be initiated using this function. (see the RESIDENT DATA LOGGING section of this manual for further detail.)

After setting the scan interval, the **TUNE** knob must be pressed to start the data log. Once started, the **FREQUENCY/CHANNEL** readout displays the frequency under test. The **FREQUENCY/CHANNEL** readout will increment as the measurements are recorded. After recording all measurements, the meter will shut off until the scan interval has expired. At that time the meter will automatically power itself up and perform the next data log. After recording all measurements, the meter will again shut itself off. If twenty records have been recorded, the meter will remain off until manually powered up by the operator.

One (1) of two (2) conditions determines at which frequency the data log record will end. If the SCAN STOP FREQUENCY (F9) is reached, the data log ends after recording the SCAN STOP FREQUENCY. If prior to reaching the SCAN STOP FREQUENCY the maximum number of readings is reached, the data log will end then, regardless of the last frequency recorded.

The maximum number of readings each data log record will hold is 360, no matter which SCAN STEP FREQUENCY (F7) is selected.

The amount of time required to record 360 entries cannot be guaranteed. The minimum time required to tune, measure and record 360 different frequencies is around 2 minutes. If the signals being measured have wide amplitude differences, the instrument must make adjustments for this by switching internal RF relays. These range changes may significantly increase the time required to completely record a long data log record.

NOTE: Starting F10 resets the Record Counter to one, "R1" All previously stored records will be erased.

F11: MANUAL CONTIGUOUS RESIDENT DATA LOG

Initially, this function displays the record number to be logged in the **FREQUENCY/CHANNEL** readout, "R 1 xx.xxx MHz", the "R 1" indicates the first record, R1 if no records have been previously stored or "R 2", "R 3", ... up to "R20", if all 20 records have already been stored. The "xx.xxx" indicates the SCAN START FREQUENCY.

The **TUNE** knob must be pressed to start the data log. Once started, the **FREQUENCY/CHANNEL** readout displays "LOG xxx.xxx MHz" where "xxx.xxx" is the current frequency under test. The **FREQUENCY/CHANNEL** readout will increment as the measurements are recorded.

After recording all readings, the meter will beep twice. The **FREQUENCY/CHANNEL** readout will display "END R .100" where ".100" indicates end of record #1. The operator has two (2) choices at this point. If the **MEMORY** button is pressed, the record will be stored. If the **FUNCTION** button is pressed, the record will be discarded.

The conditions for determining at which frequency the data log record will end are the same as for the F10 function.

The maximum number of records which can be stored in the R-505C is twenty, "R20". If the operator has already stored 20 records, selecting function F11 again will cause the meter to beep three (3) times and exit back to normal Field Strength Meter (FSM) mode.

Function F91 should be used to reset the record counter back to one (1).

F15: SELECT ATTENUATOR SETTING

This function is used to lock the meters internal RF ATTENUATORS at a single setting or to unlock them to enable the meter to Auto-range. If a signal is known to be always within a 35 to 40 dB range locking the appropriate attenuator allows the meter to make faster measurements. Entering this function shows "**ATN UNL**" in the **FREQUENCY/CHANNEL** readout when the meter is Auto-ranging. Rotate the **TUNE** knob to change the setting. Possible settings are "**ATN 0**" no attenuators locked in the RF path. "**ATN 20**" a 20 dB attenuator locked in the RF path. "**ATN 40**" a 40 dB attenuator locked in the RF path. "**ATN 60**" a 60 dB attenuator locked in the RF path.

Note: Locking the attenuators may cause an error in the **SIGNAL LEVEL** readout reading if the signal is too large or too small for that attenuator setting. This function is for advanced users only who have special measurement needs, and know the anticipated signal level.

F21: ERASE USER MEMORY (1-10)

All USER MEMORY locations may be erased from non-volatile memory by entering the F21 function.

Select function F21. The phrase "3 ERAS" will be displayed in, and in the **FREQUENCY/CHANNEL** readout.

As a safety measure, the **MEMORY** button must be pressed three times in sequence to activate this function. Each NORMAL operation of the **MEMORY** button decrements the number shown in the **FREQUENCY/CHANNEL** readout. The third depression erases the USER MEMORY settings. The erase procedure may take several seconds to complete if all 10 user memory location are being erased. This feature is handy when performed immediately prior to completely changing all of the 10 USER MEMORY settings.

F28: SOFTWARE VERSION #

Function 28 displays the meters software release date and version number in the **FREQUENCY/CHANNEL** readout. Example: "3.00 898" Software version number 3.00, release date August, (the 8th month) of the year 1998.

F40: (Locked User Functions)

CUSTOMER CALIBRATION (MAJOR)

NOTE: See function F59 to unlock functions F40 through F48.

F40 function allows the user to perform a full, multi-point calibration. The calibration procedure requires an IBM PC compatible computer running Z-Technology special R-505C Calibration software and communicating with the R-505C over the RS-232 serial port.

The resulting user-generated calibration table is used in the place of the factory provided calibration table whenever function F41 is selected. As with the single-point calibration, the multi-point calibration table values will be used in calculating the true signal level before the level is shown on the **SIGNAL LEVEL** readout.

For complete information, see the instructions supplied with the R-505C Calibration Software.

F41: (Locked User Function) SELECT CUSTOMER CALIBRATION TABLE

NOTE: See function F59 to unlock functions F40 through F48.

Selecting the F41 mode causes the R-505C to substitute the User Calibration Table for the factory calibration table. This function is not executable if the User Calibration Table is empty or contains invalid data.

If the F41 mode is selected and the User Calibration Table contains invalid data, three (3) short beeps will be heard and the unit will default to the factory calibration table.

F42: (Locked User Function) SELECT FACTORY CALIBRATION TABLE

NOTE: See function F59 to Unlock functions F40 through F48.

Invoking Function F42 mode selects the Factory Calibration Table. Three (3) short beeps when the function is invoked indicates that the Factory Calibration Table contains invalid data. If this happens, contact Z Technology, or your service center to return the unit for re-calibration.

F43: (Locked User Function) SET RS-232 BAUD RATE

NOTE: See function F59 to unlock functions F40 through F48.

When function F43 is selected, the current BAUD rate (1200, 2400 or 9600) is displayed in the **FREQUENCY/CHANNEL** readout. Rotating the **TUNE** knob will roll through the available rates.

Use the NORMAL operation of the **FUNCTION** button to set the BAUD rate, store it in the non-volatile memory (for use at the next power-up), and exit this mode.

F44: SET RS-232 REMOTE ADDRESS

To display/set the remote address for this meter, select function F44 mode. The **FREQUENCY/CHANNEL** readout will show the phrase "ADR 1" in the case the current address 1 valid addresses are (0-255). The factory default is 1.

Rotate the **TUNE** knob to change the address setting.

The NORMAL operation of the **FUNCTION** button stores the new address in non-volatile memory and exits the F44 function.

F45: (Locked User Function) SET 24-HOUR CLOCK

NOTE: See function F59 to unlock functions F40 through F48.

Section 6: Function Features

Data Logging has to be enabled to use this function. See the section titled *Resident Data Logging* for details.

To display/set the 24-hour clock, select the F45 mode. The time will be displayed in the **FREQUENCY/CHANNEL** readout. The first two digits are the hours (00-23) the next two digits are the minutes (00-59)

The NORMAL operation of the **TUNE** knob toggles the cursor between the hours and minutes. Rotating the **TUNE** knob changes the time setting.

The NORMAL operation of the **FUNCTION** button will set the clock and exit the F45 mode.

F46: (Locked User Function) SET MONTH/DAY

NOTE: See function F59 to unlock functions F40 through F48.

Data Logging has to be enabled to use this function. See the section titled *Resident Data Logging* for details.

To display/set the month and/or day, select the F46 mode. The **FREQUENCY/CHANNEL** readout will show a numeric month and day. For example "09:02". In this case September 2nd, the 9th month, the 2nd day.

The NORMAL operation of the **TUNE** knob toggles the cursor between months and days. Rotating the **TUNE** knob changes the date setting.

The NORMAL operation of the **FUNCTION** button sets the date and exits the F46 mode.

F47: (Locked User Function) SET YEAR

NOTE: See function F59 to unlock functions F40 through F48.

Data Logging has to be enabled to use this function. See the section titled *Resident Data Logging* for details.

To display/set the year, select the F47 mode. The **FREQUENCY/CHANNEL** readout will show for example "YR 1998".

Rotating the **TUNE** knob changes the year setting. (Note: The year may not be set less than 1992.)

The NORMAL operation of the **FUNCTION** button stores the date in non-volatile memory and exits the F47 mode.

F48: CLONE ANOTHER R-505C

The "clone" mode, F48, allows an operator to copy USER MEMORY contents, CHANNEL PLANS, etc., from one R-505C to another. This function greatly reduces the time needed to set up a number of instruments.

Set both R-505C's to the same address. See F44.

Connect the "Master" R-505C (an instrument already containing the desired settings) to the "Clone" R-505C using the RS-232C cloning cable.

Set the baud rate of BOTH units to 9600 baud using function F43.

Set the Clone to function F93.

Set the Master to function F48. Selecting the function (pressing the **TUNE** knob) initiates the cloning process.

F59: UNLOCKS USER FUNCTIONS F40 - F48

Function F59 when properly executed allows the user access to F40 - F48, the "Locked Out User Functions". To unlock, the user must perform F59 three (3) times in sequence. This is accomplished by the following:

Push the **FUNCTION** button, then rotate the **TUNE** knob until the **FREQUENCY/CHANNEL** readout displays "**F59**". Execute F59 by pressing in the **TUNE** knob. This has just performed Function F59 one (1) time. Repeat this process two (2) more times.

Functions F40 through F48 are now available to be accessed and desired changes can be made.

To again lock out F40 through F48 and prevent inadvertent changes simply cycle the instrument's power **POWER** off and back on.

F91: RESET DATA RECORD COUNTER

Selecting this function resets all data log record counters to one (1), effectively erasing all data log records of any type.

Select function F91. The phrase "**3 RSET**" will be displayed in, and in the **FREQUENCY/CHANNEL** readout.

As a safety measure, the **MEMORY** button must be pressed three times in sequence to activate this function. Each **NORMAL** operation of the **MEMORY** button decrements the number shown in the **FREQUENCY/CHANNEL** readout. The third depression resets the data record counter to one (1).

F93: REMOTE MODE

The F93 mode sets up R-505C to communicate with a host personal computer (PC). See the section of this manual entitled "R-505C Data Logging Application Guide".

F93 is also used to "clone" another R-505C. See function F48 above.

PRINTING RECORDED DATA

At any time a scan is not taking place, recorded data may be transferred to a printer, via the RS-232 port. See function F93 for instructions for transferring data to a PC.

Section 6: Function Features

Two (2) functions, F94 and F95 are available for transferring records to a printer, or PC.

F94: PRINT (RS-232) SELECTED DATA LOG RECORD

Output a selected formatted record, via the RS-232 port. You can select from record 1 - 20 when collecting data through use of F10 & F11; or record 1-24 when collecting data through F96 or F98.

Select F94, the **FREQUENCY/CHANNEL** readout displays "**F94 R1**", (the first record number). If the **FREQUENCY/CHANNEL** readout simply goes back to the frequency or channel number than there are no records saved to print out.

Rotating the **TUNE** knob advances the record number. Pressing the **TUNE** knob selects the record and starts the transfer process.

NOTE: The resulting report format is determined by the RESIDENT DATA LOGGING MODE used to capture the data. Examples of report format are shown in the RESIDENT DATA LOGGING section later in this manual. If data was captured with the meter in FREQUENCY mode, the corresponding frequency will be reported. If data was captured with the meter in CHANNEL mode, the corresponding channel will be reported.

F95: PRINT (RS-232) ALL DATA LOG RECORDS

Output all formatted records, via the RS-232 port. If data was collected using F10 or F11, Records 1 - 20 will be reported. If data was collected using F96 or F98, Records 1-24 will be reported.

Select F95, the **FREQUENCY/CHANNEL** readout displays "**ALL Rx**," where "x" is the number of records. Pressing the **TUNE** knob starts the transfer process.

NOTE: The resulting report format is determined by the RESIDENT DATA LOGGING MODE used to capture the data. Examples of report format are shown in the RESIDENT DATA LOGGING section later in this manual. If data was captured with the meter in FREQUENCY mode, the corresponding frequency will be reported. If data was captured with the meter in CHANNEL mode, the corresponding channel will be reported.

F96: AUTO - USER MEMORY RESIDENT DATA LOGGING

This function scans and records the carrier levels of the frequencies or channels stored in USER MEMORY. Up to 24 scans will occur, separated by a user-set time interval of 1 to 360 minutes, settable in 1 minute steps.

Procedure:

1. Select F96, the **FREQUENCY/CHANNEL** readout now displays "**001 AUTO**" where "**001**" represents the current setting for minutes-between-scans. "**AUTO**" indicates AUTO RESIDENT DATA LOGGING.

2. Rotate the **TUNE** knob to display the desired time interval.
3. Pressing the **TUNE** knob resets the record counter to the first (#1) record and starts the scanning process.

NOTE: ALL PREVIOUSLY STORED DATA, INCLUDING ANY DATA LOG MEASUREMENTS, WILL BE LOST!

4. The **SIGNAL LEVEL** readout will now display the message, "LOG **xxx.xxx MHz**" and **FREQUENCY/CHANNEL** readout where "**LOG**" indicates the meter is logging readings, **xxx.xxx** is the current frequency or channel currently being scanned. In the case of channels, only the picture **or** audio carrier level will be recorded, which ever one was active when that memory location was programmed.
5. At the completion of each scan, the data is automatically stored in non-volatile memory and the R-505C powers down.
6. At a signal from its real-time clock the R-505C powers-up when it is time for the next scan.
7. After the last scan, the unit shuts off and remains off until manually powered up by the user.

NOTE: The amount of time needed to measure and record carrier levels depends both on the number of carriers and on the signal level variation between them. When all carrier levels are within normal, usable limits, the R-505C can log up to 100 channels in less than 1 minute. However, if more than 50 frequencies or channels are present and signal levels vary more than 20 dB, the time interval should be set to 3 minutes or greater.

NOTE: The R-505C can be manually powered up between scans. Selecting other functions or powering off during a scan will abort the AUTO - USER MEMORY RESIDENT DATA LOGGING mode. However, the data for all completed scans remains in non-volatile memory, and can be downloaded through the RS-232C port.

See the RESIDENT DATA LOGGING SECTION of this manual for further explanation.

F98: MANUAL - USER MEMORY RESIDENT DATA LOGGING

This function scans and records the carrier levels of the frequencies or channels stored in USER MEMORY. One record is filled each time this function is executed. Procedure:

1. Select F98, the **FREQUENCY/CHANNEL** readout now displays "R 1n **xxx.xxx MHz**" where the "n" is the record number to be filled, and "**xxx.xxx**" is the frequency or channel stored in the first USER MEMORY location.
2. Pressing the **TUNE** knob starts the scanning process.
3. The **FREQUENCY/CHANNEL** readout will now display the message, "LOG **xxx.xxx MHz**" where "**LOG**" indicates the meter is logging data, "**xxx.xxx**" is the frequency or channel

Section 6: Function Features

currently being measured. In the case of channels, only the picture **or** audio carrier level will be recorded, whichever one was active when that memory location was programmed.

4. At the completion of the scan, The **FREQUENCY/CHANNEL** readout displays "**END Rn**" where "n" is the record number to be filled. Press the **MEMORY** button to store the record in non-volatile memory, any other button discards the record.
5. To start another scan go back to step one.

See the RESIDENT DATA LOGGING SECTION of this manual for further explanation.

Section 7: Resident Data Logging

NOTE: To use the RESIDENT DATA LOGGING Feature, it must first be activated through the RS-232 port. This is done by using the Quick Basic Control Software disk provided with each R-505C. The activation procedure is described in detail by the application note titled: R-500 Series Quick Basic Control Software. See the description concerning the program MENU.EXE and Setup Address 1888.

What Is RESIDENT DATA LOGGING?

The user needs to clearly understand what is meant by **RESIDENT DATA LOGGING**. **RESIDENT** simply refers to measurement information being stored inside (resident to) the R-505C. All **DATA LOGGING** is done in sessions.

A **DATA LOGGING SESSION** is an automated scan of a pre-programmed set of frequencies or channels where signal level measurements are taken and recorded at each frequency or channel. Signal level measurements are stored inside the R-505C.

An operator using the R-505C in the field may be in conditions which require the R-505C to be used stand alone, not attached to a PC via the RS232 serial port. In these situations, the operator can use front panel controls to initiate RESIDENT DATA LOGGING sessions to automatically collect extensive measurement information, and store it in the R-505C's non-volatile memory.

Following a RESIDENT DATA LOGGING session the R-505C can be powered down and transported to a laboratory. In the laboratory, the R-505C can be powered up and instructed via the front panel buttons to send a report of the logged data to the RS-232 serial port. A printer or a computer may be connected to the RS-232 serial port. Once printed or captured by a computer, the data may be further analyzed. (See the R-505C RESIDENT DATA LOGGING APPLICATION GUIDE later in this manual.)

NOTE: The R-505C RS-232 COMMAND PROTOCOL allows a computer to interrogate the R-505C directly, whereby measurement information is sent immediately to the computer. (See the Application Note: R-500 Series Quick Basic Control Software.)

The RS-232 COMMAND PROTOCOL also allows RESIDENT DATA LOGGING sessions to be initiated by a connected computer. (See Commands 25, 46, and 47 in the R-505C RS-232 COMMAND PROTOCOL section later in this manual.)

During a RESIDENT DATA LOGGING session the R-505C will scan a pre-programmed set of frequencies or channels starting at the first in the set, incrementing to the last in the set. The set may be pre-programmed by the user, or programmed to an Industry standard set. There are **TWO (2)** distinct pre-programmed sets of frequencies, each with its own features. The three pre-programmed sets are:

- **CONTIGUOUS** frequencies

Section 7: Resident Data Logging

- **USER MEMORY** frequencies

CONTIGUOUS frequency, RESIDENT DATA LOGGING (F10, F11.) referred to as **CONTIGUOUS DATA LOGGING**. All signal level measurements are at frequencies determined by user programmed step size (F7), start frequency (F8), and stop frequency (F9). This yields a set of contiguous frequency readings. (See Example 1, and Example 2 later in this section.)

USER MEMORY frequency, RESIDENT DATA LOGGING (F96, F98), referred to as **USER MEMORY RESIDENT DATA LOGGING**. All signal level measurements are at those frequencies stored in the USER MEMORY locations (1-10). The frequencies may represent user programmed radio broadcast frequencies, television channel picture frequencies, television channel audio frequencies, or some other important frequencies. The frequencies may be stored in USER MEMORY in any order. The scan will start at the frequency stored in the USER MEMORY location #1, step to the frequency stored in USER MEMORY location #2, and so on, until the last programmed USER MEMORY location has been used. This will yield a set of readings that could be all radio broadcast frequencies, all television frequencies, or some combination.

NOTE: Television channels generally have two frequencies associated with them. One for picture carrier, one for audio carrier. When a television channel is programmed into a USER MEMORY location, (i.e. In Channel mode when programming) only the picture frequency **or** audio frequency is captured (which ever one was active when the USER MEMORY location was programmed.) When USER MEMORY RESIDENT DATA LOGGING only the captured frequency will produce a signal level reading. The report generated will show a zero level for the other television channel frequency. The report will also show what CHANNEL PLAN the channel was captured from. (See Example 3 later in this section.)

Each of the two types of data logging, **CONTIGUOUS RESIDENT DATA LOGGING**, and **USER MEMORY RESIDENT DATA LOGGING** have both a manual, and an automatic implementation. (See the Function Features section earlier in this manual.)

Common Setup Parameters

Front Panel Pre-settings

Before beginning a Resident Data Logging session, the user must prepare for the session by pre-setting some front panel controls. The controls to be pre-set are:

RF AMP ("ON" or "OFF")
BANDWIDTH ("NB" or "WB")

These front panel controls are not changed by the Resident Data Logging process. Thus, the operator will want to choose an **RF AMP** setting as dictated by the expected power levels to be measured. Also, depending on the type of signal to be measured, the **BANDWIDTH** control must be preset.

For all the controls mentioned in this section, see the part of this manual on FRONT PANEL OPERATION for more details on usage.

Description Of CONTIGUOUS RESIDENT DATA LOGGING

This mode provides a contiguous sampling and logging of a series of equally spaced frequencies. The CONTIGUOUS RESIDENT DATA LOGGING mode is initialized by utilizing functions F7, F8, F9, F10, and F11. Signal level measurements are taken and stored for any user selected series of frequencies defined by start and stop points. It also lets the user choose the step size between measurement points. The step size can range from 10kHz to 500kHz.

The following describes in detail how to use the CONTIGUOUS RESIDENT DATA LOGGING mode to measure and store signal levels along with frequencies. Later the information is retrieved from the R-505C by downloading it into an IBM compatible PC.

Using The CONTIGUOUS RESIDENT DATA LOGGING Functions:

Functions F7, F8 and F9 must be set before attempting to log data using this method. F7 sets the Scan Frequency Step Size which can be at any 10kHz interval from 10kHz to 500kHz. F8 and F9 set the Scan Start Frequency and Scan Stop Frequency respectively. These frequencies can be any valid R-505C measurement frequency.

This Data Logging mode has a limit of 360 data points per recorded. Twenty (20) data records can be stored in the R-505C at any one time.

As an example, assume F8 (Start Frequency) is set for 879.00MHz and F9 (Stop Frequency) is set for 889.80MHz. Let's also use F7 (Scan Step Frequency) to choose 30kHz as the step size between measured frequencies. This would create a set of exactly 360 data points (signal strength measurements) to be logged.

Functions F10 and F11 are the functions used to initiate CONTIGUOUS RESIDENT DATA LOGGING records.

F10 AUTO - CONTIGUOUS RESIDENT DATA LOGGING, allows the user to perform up to twenty (20) logging sessions. Each record separated in time by 5 minutes to 24 hours. Records are stored in the R-505C to be downloaded to a printer or PC. Starting a new Logging session resets the record counter, effectively erasing the old data.

F11 MANUAL - CONTIGUOUS RESIDENT DATA LOGGING, is similar to F10 except that it records only one data record at the time the user executes the function itself.

A summary of using functions F7 through F11 follows:

Setting Step Size, Start and Stop Frequencies.

1. Push the **FUNCTION** Button on the front panel.
2. Turn the **TUNE** knob until "**F7**" is displayed.
3. Select "**F7**" by pushing the **TUNE** knob once.
4. Increment/Decrement the number displayed to your choice of Scan Freq. Step Size --- 10 to 500 kHz.
5. Press the **FUNCTION** Button to exit and store your choice.

Section 7: Resident Data Logging

6. Push the **FUNCTION** Button again.
7. Turn the **TUNE** knob until “**F8**” is displayed.
8. Select F8 by pushing the TUNE knob once.
9. Adjust the **TUNE** knob to the Start Frequency desired.
10. Press the **FUNCTION** Button to exit and store this choice.
11. Push the **FUNCTION** Button again.
12. Turn the **TUNE** knob until “**F9**” is displayed.
13. Select F9 by pushing the **TUNE** knob once.
14. Adjust the **TUNE** knob to the Scan Stop Frequency desired.
15. Press the **FUNCTION** Button to exit and store this choice.

Performing the Actual Data Logging Run(s)

Using F10: AUTOMATIC (timed) CONTIGUOUS RESIDENT DATA LOGGING

1. Connect the signals to be measured at the Type-N connector on the R-505C front panel.
2. Push the **FUNCTION** Button on the front panel.
3. Turn the **TUNE** knob until “**F10**” is displayed.
4. Press the **TUNE** knob. “**LOG :05**” is displayed in the *FREQUENCY/CHANNEL* readout. “:05” indicates 5 minute intervals between measurement sessions.
5. Rotate the **TUNE** knob to incrementing the number to select the time interval desired between Auto Log records. This time can be incremented from 5 minutes to 24 hours in 1-minute steps.
6. To initiate the scan process, press the **TUNE** knob.
7. The R-505C will immediately start its first scan.
8. When this scan is over the unit will automatically turn off. It will wait for the time interval (set above) and then automatically turn on and perform another scan. This process will repeat -- up to 20 times or until the operator terminates the cycle by manually taking the R-505C out of the AUTO CONTIGUOUS DATA LOGGING mode.
9. After the twentieth scan the unit will turn off and stay off, until manually powered up by an operator.

Using F11: MANUAL CONTIGUOUS DATA LOGGING

1. Connect the signals to be measured at the Type-N connector on the R-505C front panel.

2. Push the **FUNCTION** Button on the front panel.
3. Turn the **TUNE** knob until "**F11**" is displayed.
4. Press the **TUNE** knob. The **FREQUENCY/CHANNEL** readout will display the record number to be logged "**R 1 xxx.xxx MHz**". The "**1**" indicates the record number, the number will increment as records are stored. (indicating record R1) if no records have been stored, The "**xxx.xxx**" indicates the Start frequency.
5. Press the **TUNE** knob to start the data log. "**LOG xxx.xxx MHz**" will be displayed on the **FREQUENCY/CHANNEL** readout. "xxx.xxx" is the frequency currently being measured.
6. When recording is complete, the frequency in the **FREQUENCY/CHANNEL** readout will stop incrementing and the unit will beep two times.
7. Press the **MEMORY** Button to store this new log record. (Pressing the **FUNCTION** button will discard the new record).
8. Note: Twenty records can be stored using F11 (R1,R2,R3,..R20). If all records are already filled with stored data, selecting F11 will cause three (3) beeps to sound. To discard previous records, Function F91 must be used to reset.

To Down Load Stored Data Log use Functions F94 or F95

See information to use these functions in the previous section.

Section 7: Resident Data Logging

EXAMPLE 1: Report format of **CONTIGUOUS DATA LOGGING** F10 or F11.
Printed using F94.

Z-Technology
Version: 3.00

Date: 9/02/98
Time: 14:15
Record: 1
Step: 30KHz

Freq.	Level	Freq.	Level	Freq.	Level	Freq.	Level
879.39	-10.0	879.42	-10.0	879.45	-4.1	879.48	5.6
879.51	18.7	879.54	4.5	879.57	-5.7	879.60	-9.2
879.63	-7.6	879.66	-1.3	879.69	10.9	879.72	44.0
879.75	5.8	879.78	-2.1	879.81	-7.3	879.84	-8.4
879.87	-4.4	879.90	3.2	879.93	14.9	879.96	7.1
879.99	-1.4	880.02	4.1	880.05	-10.0	880.08	-7.9
880.11	.3	880.14	11.7	880.17	40.8	880.20	4.1
880.23	-2.9	880.26	-9.2	880.29	-8.5	880.32	1.6
880.35	13.9	880.38	35.8	880.41	1.5	880.44	-5.3
880.47	-10.0	880.50	-9.7	880.53	-2.9	880.56	7.9

EXAMPLE 2: Report format of **CONTIGUOUS DATA LOGGING** F10 or F11.
 Printed using F94.

Z-Technology							
Version: 3.00							
Date: 9/02/98							
Time: 14:20							
Record: 1							
Step: 200KHz							
Freq. Level		Freq. Level		Freq. Level		Freq. Level	
88.10	27.3	88.30	29.3	88.50	29.2	88.70	27.6
88.90	29.6	89.10	28.6	89.30	27.2	89.50	27.2
89.70	27.4	89.90	29.6	90.10	26.3	90.30	26.1
90.50	29.8	90.70	43.3	90.90	26.3	91.10	25.4
91.30	34.5	91.50	53.6	91.70	25.0	91.90	34.1
92.10	34.2	92.30	43.8	92.50	25.7	92.70	27.1
92.90	27.0	93.10	25.9	93.30	25.8	93.50	44.4
93.70	51.1	93.90	25.8	94.10	24.4	94.30	26.0
94.50	26.8	94.70	26.9	94.90	27.3	95.10	27.8
95.30	28.1	95.50	32.7	95.70	25.7	95.90	25.9
96.10	24.9	96.30	25.7	96.50	27.1	96.70	28.5
96.90	37.1	97.10	45.0	97.30	25.0	97.50	24.1
97.70	23.9	97.90	29.0	98.10	26.6	98.30	28.2
98.50	35.5	98.70	25.6	98.90	24.2	99.10	24.1
99.30	31.8	99.50	42.7	99.70	22.4	99.90	27.5
100.10	44.0	100.30	57.6	100.50	48.0	100.70	15.2
100.90	21.4	101.10	57.2	101.30	49.3	101.50	14.4
101.70	19.6	101.90	67.2	102.10	54.3	102.30	19.1
102.50	29.1	102.70	33.5	102.90	16.7	103.10	18.3
103.30	62.2	103.50	52.1	103.70	14.4	103.90	10.0
104.10	13.5	104.30	14.3	104.50	22.4	104.70	31.0
104.90	20.3	105.10	34.3	105.30	28.1	105.50	20.5
105.70	22.6	105.90	20.4	106.10	23.6	106.30	20.1
106.50	23.7	106.70	35.9	106.90	27.9	107.10	17.4
107.30	22.6	107.50	52.7	107.70	44.7	107.90	16.4

Description of USER MEMORY DATA LOGGING

This mode provides measurement and logging of the frequencies or channels stored in the USER MEMORY. It is intended for those wish to log or continually monitor a few or many specific frequencies, specific cellular telephone frequencies, radio broadcast frequencies, television channels , or any combination of these categories.

F96 - AUTO USER MEMORY RESIDENT DATA LOGGING allows the user to perform up to twenty (24) logging sessions. Each record starting time separated by 1 minute to 360 minutes. Records are stored in the R-505C to be downloaded to a printer or PC. Starting a new Logging session resets the Record Counter, effectively erasing any existing data.

F98 - MANUAL USER MEMORY RESIDENT DATA LOGGING is similar to F96 except that it records only one data record at the time the user executes the function itself.

The following describes in detail how to use the USER MEMORY RESIDENT DATA LOGGING mode to measure and store signal levels along with frequencies. Later, the information can be retrieved from the R-505C by downloading it to a printer, or a PC.

Using The USER MEMORY RESIDENT DATA LOGGING Functions:

The number of entries per record in USER MEMORY RESIDENT DATA LOGGING mode is set by the number of user programmable memory locations, up to 100 entries per record. Twenty-four (24) data records can be stored in the R-505C at any one time.

A summary of using functions F96 and F98 follows:

Performing the Actual Data Logging Run(s)

Using F96: AUTOMATIC (timed) USER MEMORY RESIDENT DATA LOGGING

1. Connect the signals to be measured at the Type-N connector on the R-505C front panel.
2. Push the **FUNCTION** Button on the front panel.
3. Turn the **TUNE** knob counter clockwise until "**F96**" is displayed.
4. Press the **TUNE** knob. "**001 AUTO**" is displayed in the **FREQUENCY/CHANNEL** readout.
5. Rotate the **TUNE** knob, incrementing the number, to select the time interval time desired between Auto Log records. This time can be incremented from 1 minute to 360 minutes in 1 minute steps.
6. To initiate the scan process, press the **TUNE** knob.
7. The R-505C will immediately start its first scan.
8. When this scan is over, the unit will automatically turn off. It will wait for the time interval (set above) and then automatically turn on and perform another scan. This process will

repeat -- up to 24 times or until the operator terminates the cycle by manually taking the R-505C out of the AUTO - USER MEMORY RESIDENT DATA LOGGING mode.

9. After the twenty-fourth scan the unit will turn off and stay off, until manually powered up by an operator.

Using F98: MANUAL USER MEMORY DATA LOGGING

1. Connect the signals to be measured at the Type-N connector on the R-505C front panel.
2. Push the **FUNCTION** Button on the front panel.
3. Turn the **TUNE** knob counter clockwise until F98 is displayed.
4. Press the **TUNE** knob. The **FREQUENCY/CHANNEL** readout will display "R 1xxx.xxx MHz". "R 1" is the record number to be logged ("R 1" if no records have been stored, "R 2", "R 3", "R 4", etc. if previous records have been stored.) "xxx.xxx" is the Frequency or Channel of the #1 USER MEMORY location.
5. Press the **TUNE** knob to start the data log. "LOG xxx.xxx MHz" will be displayed on the **FREQUENCY/CHANNEL** readout. "xxx.xxx" is the frequency or channel currently being measured.
6. When recording is complete, "END R 1" will be displayed in the **FREQUENCY/CHANNEL** readout, and the unit will beep two times. "R 1" will increment as records are stored.
7. Press the **MEMORY** Button to store this new log record. (Pressing the **FUNCTION** button will discard the new record).
8. Note: Twenty-four records can be stored using F98 ("R1", "R2", "R3", "R24"). If all records are already filled with stored data, selecting F98 will cause three (3) beeps to sound. To discard all previous records, Function F91 must be used to reset.

To Down Load Stored Data Log use Functions F94 or F95

See information to use these functions in the previous section.

Section 7: Resident Data Logging

EXAMPLE 2: Report format of **USER MEMORY RESIDENT DATA LOGGING** F96 or F98.
Printed using F94.

Z-Technology
Version: 3.00

Date: 9/02/98
Time: 14:22
Record: 1

Channel	Frequency	Picture	Audio	Level	Plan
-					
6	1.10 MHz	53.8	.0	50.8	AIR
					AIR
	106.70 MHz			34.9	AIR
10		80.3	.0		AIR
10		.0	77.2		AIR
12		80.8	.0		L1
12		.0	75.4		L1
95		.0	23.2		HRC
96		25.1	.0		IRC
97		60.5	.0		NCTA

Section 8: Data Logging Application Guide

This guide is meant to help the user set up a printer or computer to accept data from an R-505C.

The R-505C has several levels of intelligence incorporated. To this point in the manual, we have focused on operation the instrument directly from the front panel controls. We have only mentioned the serial port in passing. This section and the sections to follow focus on control and/or retrieval of information through the RS-232 port.

The standard R-505C can download data to a serial printer directly, or to a computer running any of the common communications software packages (i.e. Procomm, WinTerm, HyperTerminal, etc.) Once captured, PC text files can be imported into any of several commercially available spreadsheet programs for deeper analysis.

If you have trouble getting your computer or printer to operate properly, review the list of common problems and their causes at the end of this note. If you still have problems, please communicate with the factory to allow us to help. Z Technology Inc.'s telephone: 1-503-614-9800; fax 1-503-614-9898.

Please collect the following information to provide us in the fax or during the call.

- 1) The R-505C's serial number.
- 2) The version of firmware in the R-505C. See description of function F28 for instructions on how to determine firmware version.
- 3) Whether or not you are using a Z Technology Inc. Cable.
- 4) The specifications of the printer you are downloading to, or:
- 5) The configuration of the computer you are downloading to, especially whether it is equipped with a mouse or trackball.
- 6) Other software that might be resident in your computer, especially "terminate and stay resident" (TSR) software.
- 7) The version of DOS and/or Windows your computer contains.

Installation and Setup:

Connecting The R-505C to a Printer:

Using the R-505C printer interface cable, connect the R-505C to the serial input port of the printer. (See the diagrams at the end of this section to build your own cable with the proper pin to pin connections).

NOTE: The R-505C will not drive a parallel-input printer.

Set the R-505C to 1200, 2400, or 9600 baud by following the procedure outlined below.

Turn on the R-505C

Unlock communications settings using F59

Press **FUNCTION** button.

Using **TUNE** knob dial to “**F59**”

Press **TUNE** knob to select, R-505C will return to previous operating mode.

Repeat steps (1) through (3) two more times.

Press **FUNCTION** button.

Using the **TUNE** knob, dial to “**F43**”.

press **TUNE** knob to select. R-505C will now display the baud rate.

To change baud rate, turn **TUNE** knob.

Press **FUNCTION** button to set R-505C to whichever baud rate is currently displayed and return the R-505C to the previous function.

Set the printer communication parameters to match that of the R-505C. See your printers manual for instructions.

BAUD RATE: 1200, 2400, or 9600. (Set to match that selected above)

PARITY: no parity.

NUMBER OF DATA BITS: 8

STOP BITS: 1

If the printer can emulate several types of printers, set for "IBM".

Connecting the R-505C to a Computer:

NOTE: The simplest way to capture R-505C Report information with your PC is to use a Terminal Emulator Communication package on your computer. Packages such as Procomm, for DOS only computers, WinTerm which is in the Accessories group in Windows 3.1, or HyperTerminal in the Accessories folder in Windows 95 or Windows 98 all allow you to capture text to a file. They also allow you to send RS-232 data directly to a printer.

Set the R-505C to 1200, 2400, or 9600 baud by following the procedure outlined below.

- ◆ Turn on the R-505C
- ◆ Unlock communications settings using F59
- ◆ Press **FUNCTION** button.
- ◆ Using **TUNE** knob dial to “**F59**”
- ◆ Press tune knob to select, R-505C will return to previous operating mode.
- ◆ Repeat steps (1) through (3) two more times.
- ◆ Press **FUNCTION** button.
- ◆ Using the **TUNE** knob, dial to “**F43**”.
- ◆ press **TUNE** knob to select. R-505C will now display the baud rate.
- ◆ To change baud rate, turn **TUNE** knob.
- ◆ Press **FUNCTION** button to set R-505C to whichever baud rate is currently displayed and return the R-505C to the previous function.
- ◆ Set your Terminal Emulator communication parameters to match that of the R-505C. See your Terminal Emulator manual or help pages for instructions.
- ◆ BAUD RATE: 1200, 2400, or 9600. (Set to match that selected above)
- ◆ PARITY: no parity.
- ◆ NUMBER OF DATA BITS: 8
- ◆ STOP BITS: 1

Operation:

Sending Records to a Printer:

Verify that the printer has been set up properly and that the R-505C and printer are set to the same baud rate (see section (I), "Installation and Set Up.")

- ◆ Set up the R-505C to send data:
- ◆ Turn on the R-505C.
- ◆ Press the **FUNCTION** button.
- ◆ Using the tune knob, dial:
- ◆ **"F94"** to send a selected record, or:
- ◆ **"F95"** to print all records.
- ◆ If F95 was selected, pressing the **TUNE** knob will cause the R-505C to immediately begin sequentially sending all records to the printer.
- ◆ If F94 was selected, select the record to be printed:
- ◆ Rotate the **TUNE** knob to the desired record number.
- ◆ Press the **TUNE** knob to select record.

The R-505C will immediately begin sending the selected record to the printer.

Sending Records to a Computer:

Verify that the Terminal Emulator has been set up properly and that it and the R-505C set to the same baud rate (see section (I), "Installation and Set Up.")

Use the procedure in your Terminal Emulator's manual or help pages to set up the Emulator to receive ascii text and assign it a file name.

Transmit one or all records to the computer using the procedure below.

- ◆ Turn on the R-505C.
- ◆ Press the **FUNCTION** button.
- ◆ Using the tune knob, dial:
- ◆ **"F94"** to send a selected record, or:
- ◆ **"F95"** to print all records.
- ◆ If F95 was selected, pressing the **TUNE** knob will cause the R-505C to immediately begin sequentially sending all records to the printer.
- ◆ If F94 was selected, select the record to be printed:
- ◆ Rotate the **TUNE** knob to the desired record number.
- ◆ Press the **TUNE** knob to select record.

The R-505C will immediately begin sending the selected record to the printer.

Problems and Fixes:

Symptom:

The R-505C will not enter function F94 PRINT SELECED DATA LOG RECORD, or F95 PRINT ALL DATA LOG RECORDS.

POSSIBLE CAUSES:

- ◆ No data stored in R-505C. If no data records exist, the R-505C will not enter print mode when F94 or F95 is selected. The R-505C will emit three "beeps".
Review the procedure for CONTIGUOUS RESIDENT DATA LOGGING, or USER MEMORY RESIDENT DATA LOGGING in the DATA LOGGING section earlier in this manual. Verify that you are using the correct procedure.

Symptom:

The printer doesn't print or prints "garbage characters".

POSSIBLE CAUSES:

- ◆ The printer is not on-line. Press the printer's "on line" button to connect it to the data port.
- ◆ The data cable between the R-505C and printer is incompatible with the R-505C. The RS-232C standard allows data cables to be internally wired in several ways. The R-505C requires a standard "straight through" pin 1 to pin 1, pin 9 to pin 9 cable with a Male DB9 connector on one side, a Female DB9 connector on the other side. Use an ohmmeter to verify your cable has the correct pin-outs.
- ◆ Printer communication parameters are not set up correctly. Review "Connecting the R-505C to a printer" earlier in this section to verify that communication parameters are set correctly. If the printer has more than one emulation mode, verify that the "IBM" mode has been selected.
- ◆ Printer and R-505C are set to different baud rates. The R-505C will operate at 1200, 2400, or 9600 baud, selectable from the front panel.

To determine the current setting:

- ◆ Turn on the R-505C.
- ◆ Unlock communication settings using F59:
- ◆ Press **FUNCTION** button.
- ◆ Using **TUNE** knob dial to "**F59**".
- ◆ Press **TUNE** knob to select, R-505C will return to previous operating mode.
- ◆ Repeat steps (1) through (3) two more times.
- ◆ Press **FUNCTION** button.
- ◆ Using the **TUNE** knob, dial to "**F43**".
- ◆ Press tune knob to select. R-505C will now display the baud rate.
- ◆ To change baud rate, turn **TUNE** knob.
- ◆ Press **FUNCTION** button to set R-505C to which ever baud rate is currently displayed and return the R-505C to the previous function.

Symptom:

The R-505C doesn't communicate with computer.

POSSIBLE CAUSES:

- ◆ The data cable between the R-505C and printer is incompatible with the R-505C. The RS-232C standard allows data cables to be internally wired in several ways. The R-505C requires a standard "straight through" pin 1 to pin 1, pin 9 to pin 9 cable with a Male DB9 connector on one side, a Female DB9 connector on the other side. Use an ohmmeter to verify your cable has the correct pin-outs.
- ◆ The computer is set to the wrong Communications Port.
- ◆ If you are using a Terminal Emulator program, check to see that the Emulator is using the Communications Port the R-505C is connected to.
- ◆ If you are using the Quick Basic Control Software disk you are limited to using communications ports (1) or (2). If you are not sure which port to use, try each of them. If you still cannot verify which communication port the computer's RS-232 connector operates through, contact your computer supplier for more help.
- ◆ The computer and R-505C are set to different baud rates. The R-505C will operate at 1200, 2400 or 9600 baud. Selectable from the front panel.

To verify the setting:

- ◆ Turn on the R-505C.
- ◆ Unlock communication settings using F59:
- ◆ Press **FUNCTION** button.
- ◆ Using **TUNE** knob dial to "F59"
- ◆ Press **TUNE** knob to select, R-505C will return to previous operating mode.
- ◆ Repeat steps (1) through (3) two more times.
- ◆ Press **FUNCTION** button.
- ◆ Using the **TUNE** knob, dial to "F43".
- ◆ Press **TUNE** knob to select. R-505C will now display the baud rate.
- ◆ To change baud rate, turn tune knob.
- ◆ Press **FUNCTION** button to set R-505C to which ever baud rate is currently displayed and return the R-505C to the previous function.

Symptom:

Some or all records are scrambled during transfer.

POSSIBLE CAUSES:

- ◆ Data transmission rate problem. Even though the computer's communications software may allow you to communicate at 9600 baud, the computer itself may not be able to accept data that fast. As an experiment, try communicating at 1200 baud. To set the R-505C's baud rate:
- ◆ Turn on the R-505C.
- ◆ Unlock communication settings using F59:
- ◆ Press **FUNCTION** button.
- ◆ Using **TUNE** knob dial to "F59"
- ◆ Press **TUNE** knob to select, R-505C will return to previous operating mode.
- ◆ Repeat steps (1) through (3) two more times.

Section 8: Data Logging Application Guide

- ◆ Press **FUNCTION** button.
- ◆ Using the **TUNE** knob, dial to “**F43**”.
- ◆ Press **TUNE** knob to select. R-505C will now display the baud rate.
- ◆ To change baud rate, turn **TUNE** knob.
- ◆ Press **FUNCTION** button to set R-505C to which ever baud rate is currently displayed and return the R-505C to the previous function.

Remember to reset your computer's Terminal Emulation program to 1200 baud. Consult the manual or help pages of your Terminal Emulation program for how to verify and set the baud rate.

Symptom:

Modem conflicts

POSSIBLE CAUSES:

- ◆ The R-500 Series Quick Basic Control Software disk supports only COM1 or COM2. In DOS and Windows3.1 based systems COM1 must use the PC's hardware interrupt IRQ4, and COM2 must use hardware interrupt IRQ3. Windows 95 and Windows 98 allow COM1 and COM2 to use a number of different interrupts.
- ◆ Some internal modem cards cause COM port conflicts. The modem cannot be addressed to the same COM port as the R-505C. Some modem cards have the ability to be addressed to either COM3 or COM4. In DOS and Windows3.1 based systems COM1 and COM3 share interrupt IRQ4. COM2 and COM4 share interrupt IRQ3. If a modem is using COM3, and R-505C is sending DATA LOGGING information to the computer via a Terminal Emulation program set to use COM1 a conflict will occur if both devices are used simultaneously. Similarly for the case of COM2 and COM4 used simultaneously.

RS-232 Cables and Adapters

Several drawings of RS-232 I/O cables and adapters are included on the next few pages. They are for your reference and convenience as you connect your printer (and depending on the software, your PC) to the R-505C serial port. These wire configurations are unique to the R-505C and must be followed in order to correctly download stored data to a printer. In all cases, using a PC and standard straight through RS-232 cable with 9 pin connectors, will allow you to control an R-505C via the serial port.

The drawing titled "**RS-232 I/O Cable**" is used to connect the R-505C's serial port to a printer serial port or a PC's 25 pin serial COM port. This drawing is the wiring diagram for the Accessory Cable (p/n 207-698-00) listed in the accessories section of this manual.

The drawing titled "**RS-232 I/O CABLE, R-500 Series to PC AT**" is for use when connecting the R-500 Series Meter to a PC's 9 pin serial COM port. If the user chooses to build their own cable and will only be connecting the Field Strength Meter to a 9 pin COM port, this wire diagram can be used.

The drawing titled "**RS-232 ADAPTER**" converts from a 25 pin serial connector back to a 9 pin. This is a very common adapter and can be found at most computer stores. Along with the above cable, this adapter will allow a user to connect his R-505C serial port to either type of PC Serial COM connector found on almost all IBM compatible PCs.

RS-232 I/O Cable

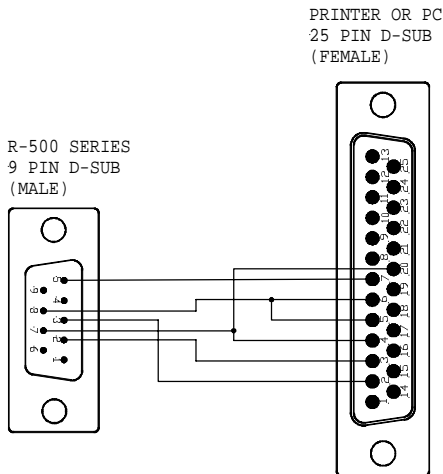

Section 8: Data Logging Application Guide

RS-232 I/O Cable R-500 Series to PC AT

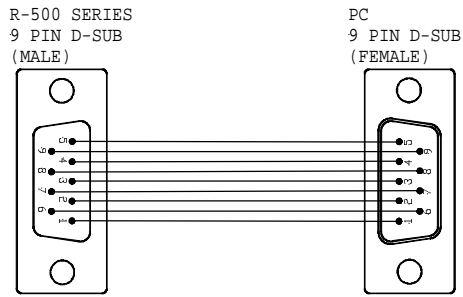

RS-232 Adapter

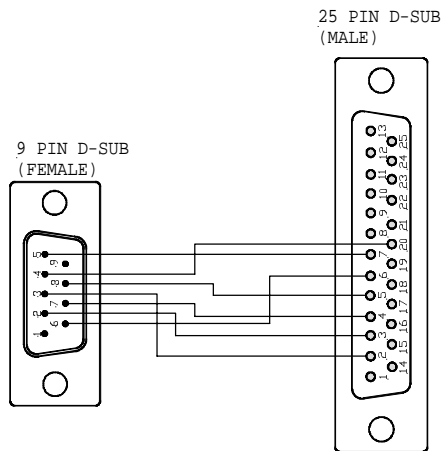

Section 9: Serial Command Protocol

The purpose to this section is to detail the operation of the serial (RS-232) port of the R-505C Field Strength Meter. This will provide the necessary information for a customer to create his own host computer communications software and control the R-505C directly through and IBM Compatible PC.

Hardware

The female, 9-pin, D-SUB connector on the rear of the R-505C provides the connection to external devices (referred to as the HOST in this manual). It's pin assignment is shown below:

PIN 1	RS-232 LABEL	DESCRIPTION
1		
2	Tx	transmit data (to host computer)
3	Rx	receive data (from host)
4		
5	SG	signal ground
6		
7	RTS	request to send (from host)
8	CTS	clear to send (to host)
9		

Software

To communicate with the R-505C, any (and all) external devices must use hardware handshaking (i.e. CTS/RTS). Data integrity cannot be guaranteed if this feature is not incorporated into the host communications software.

Each R-505C meter has its own specific address number (1-255). The operator may change this value by selecting function F44.

The R-505C 's RS-232 format is 1 start bit, 8 data bits, no parity and 1 stop bit. There are three (3) BAUD rates, 1200, 2400 and 9600, selectable by function F43. A BAUD rate of 9600 is the default (as shipped from the factory).

Communications with the R-505C, via the RS-232 port, is possible only while the R-505C is in the REMOTE state. The meter is placed in the REMOTE state by selecting function F93.

While in the REMOTE state, a R-505C will never initiate communications. The host must always start the communications by sending a command packet to the R-505C.

Commands

The following list contains **COMMAND** numbers available to the host. These are used to obtain information from and/or set parameters of the R-505C:

- 1 Change the REMOTE address of the unit
- 2 Set the serial port BAUD rate
- 3 Read the alarm time
- 4 Set the alarm time
- 5 Read the alarm date
- 6 Set the alarm date
- 7 Turn the alarm date ON
- 8 Turn the alarm date OFF
- 9 Turn the alarm ON
- 10 Turn the alarm OFF
- 12 Check power to clock I.C.
- 13 Read the time
- 14 Set the time
- 15 Read the date
- 16 Set the date
- 17 Read Data from R-505C memory
- 18 Erase the custom calibration table
- 19 Exit the REMOTE state
- 20 Set the R-505C frequency
- 24 Set & lock the attenuator range
- 25 Transfer log record to PC
- 26 Recall a USER MEMORY (0-10)
- 27 Store a USER MEMORY (0-10)
- 29 Report the state of the meter

- 30 Reset the R-505C (simulates power up)
- 31 Go to Field Strength Meter state
- 32 Unlock the attenuator range
- 33 Read the current year (offset from 1992)
- 34 Set the current year (offset from 1992)
- 35 Read the Signal Level as shown on meters LCD (calibrated)
- 37 Enable/Disable detector calibration
- 38 Enable/Disable frequency calibration
- 44 Write Data to R-505C memory
- 45 Select the channel plan for the next CHANNEL PLAN data log ¹
- 46 Start an CHANNEL PLAN data log (at a specific time)
- 47 Start a CONTIGUOUS Data Log (at a specific time)
- 55 Set RF amplifier, IF Bandwidth
- 57 Mute Audio
- 60 Set 4 frequencies to be used by Command #61
- 61 Read the signal level (dBuV) of the 4 Command #60 frequencies
- 62 Set a frequency and read the signal level (calibrated)
- 255 GLOBAL command

Command Protocol

A specific protocol has been devised for exchange of data between a host computer and a R-505C. Data must be sent in packets with a definite structure. The following is the packet structure for the host transmissions:

BYTE	VALUE	DESCRIPTION
1	1	1st synchronization byte
2	1	2nd synchronization byte
3	1	3rd synchronization byte
4	1-255	status flags from host (presently undefined)
5	1-255	R-505C's remote address
6	8-24	packet size (in bytes)
7	1-255	command

¹ USER MEMORY data log is a special case of CHANNEL PLAN data log

Section 9: Serial Command Protocol

8	0-255	1st data byte
.	.	
.	.	
23	0-255	16th data byte
24	0-255	packet checksum

The packet length is variable, depending upon the number of data bytes (if any) present in the packet. The packet size byte is a count of all bytes in the packet, including the checksum byte. Precautions should be taken by the host to insure the packet count byte is accurate and that the packet size never exceeds 24.

The checksum byte is always the last byte of the packet (not necessarily the 24th byte). The checksum is the logical compliment of an 8-bit sum of every byte in the packet (excluding the checksum byte), plus 1. The following C programming language example could be used to calculate the checksum value:

```
#define SIZE 5

unsigned char sum;

unsigned char rxbuf[24];

sum=~(rxbuf[0] + rxbuf[1] + ... rxbuf[rxbuf[SIZE]]) + 1;
```

The R-505C will respond (return a data packet to the host) to most commands received from the host, except GLOBAL commands. (GLOBAL commands are to all meters on the bus, regardless of their address.) The following is the packet structure for the R-505C transmissions:

BYTE	VALUE	DESCRIPTION
1	1	1st synchronization byte
2	1	2nd synchronization byte
3	1	3rd synchronization byte
4	1-255	status flags from R-505C (defined below)
5	1-255	R-505C's remote address
6	8-24	packet size (in bytes)
7	1-255	command (echoed from host packet)
8	0-255	1st data byte
.	.	
.	.	
23	0-255	16th data byte
24	0-255	packet checksum

The 8 bits of the STATUS FLAGS byte are updated every time the R-505C transmits a data packet to the HOST. A TRUE (bit = 1) state for any bit indicated the associated condition described below:

BIT# DESCRIPTION

7	(unused)
6	(unused)
5	ERR message is being shown on LCD display

- 4 data log timer has expired (timed out)
- 3 data log timer needs to be reprogrammed
- 2 unsuccessful read/write to the EEPROM
- 1 unable to perform last host command
- 0 (always zero)

The following is a description of each of the above R-505C's commands:

NOTE: In the following descriptions [n] signifies the packet data buffer value where n is the index into the data portion of the packet (Example: [1] specifies the 1st data byte but the 9th byte of the packet).

COMMAND 1

Changes the remote address of the R-505C. All future commands must contain the new address. The host must assume responsibility for bus conflicts with other meters with the same address.

HOST: [1] = new remote address (1-255)
R-505C [1] = new remote address

COMMAND 2

Changes the RS-232 BAUD rate. The response packet will be transmitted with the new BAUD rate setting.

HOST: [1] = 4 = 1200 BAUD
5 = 2400 BAUD
7 = 9600 BAUD
R-505C: [1] = 4 if BAUD rate has been set to 1200
5 if " " " " " " 2400
7 if " " " " " " 9600

COMMAND 3

Reads the hours and minutes of the alarm of the 24-hour data log timer.

HOST:
R-505C: [1] = hours (0-23)
[2] = minutes (0-59)

COMMAND 4

Sets the hours and minutes of the alarm of the 24-hour data log timer.

HOST: [1] = hours (0-23)
 [2] = minutes (0-59)
R-505C: [1] = hours (0-23)
 [2] = minutes (0-59)

COMMAND 5

Reads the day and month of the alarm of the 24-hour data log timer.

HOST:
R-505C: [1] = day (1-31)
 [2] = minutes (0-59)

COMMAND 6

Sets the day and month of the alarm of the 24-hour data log timer.

HOST: [1] = day (1-31)
 [2] = month (1-12)
R-505C: [1] = day (1-31)
 [2] = month (1-12)

COMMAND 7

Enables the date (day/month) feature of the 24-hour data log timer. If the alarm is enabled with this feature enabled, the alarm will only time out when the day and month match in addition to the usual hours and minutes.

HOST:
R-505C:

COMMAND 8

Disables the date feature of the 24-hour log timer.

HOST:
R-505C:

COMMAND 9

Enables (starts) the 24-hour data log timer.

HOST:

R-505C:

COMMAND 10

Disables the 24-hour data log timer.

HOST:

R-505C:

COMMAND 11

Enables the factory calibration by calculating and storing the checksums for the calibration tables in the E²PROM.

HOST:

R-505C:

COMMAND 12

Check to see if there had been a loss of power to the 24-hour data log timer. If there has, the time and date need to be reset.

HOST:

R-505C: FLAG BIT #3 = 1, if timer need to be reset.

COMMAND 13

Reads the hours and minutes of the 24-hour data log timer.

HOST:

R-505C: [1] = hours (0-23)

 [2] = minutes (0-59)

COMMAND 14

Sets the hours and minutes of the 24-hour data log timer.

HOST: [1] = hours (0-23)

Section 9: Serial Command Protocol

[2] = minutes (0-59)
R-505C: [1] = hours (0-23)
[2] = Minutes (0-59)

COMMAND 15

Reads the day and month of the 24-hour data log timer.

HOST:
R-505C: [1] = day (1-31)
[2] = month (1-12)

COMMAND 16

HOST: [1] = day (1-31)
[2] = month (1-12)
R-505C: [1] = day (1-31)
[2] = month (1-12)

COMMAND 17

Read the contents of sequential memory addresses. The address is a 16-bit value. The number of memory bytes returned is always equal to the byte count.

HOST: [1] = upper 8 bits of starting address
[2] = lower 8 bits of starting address
[3] = byte count (1-16)
R-505C: [1] = contents of address
[2] = contents of address+1
.
.
[16] = contents of address=15

COMMAND 18

Disables the customer calibration tables. CAUTION! Actually erases the customer calibration data in the E²PROM. Will enable the factory calibration, if valid. The R-505C beeps three (3) times if the factory calibration is not valid.

HOST:

R-505C:

COMMAND 19

Forces the R-505C to exit the RS-232 communications state, returning to Field Strength Meter state.

HOST:

R-505C:

COMMAND 20

Sets the frequency for the Field Strength Meter state. Frequency data must be a multiple of 1kHz. Also, the frequency data, in Hz, must be divided by 100 before transmission. The R-505C does not perform checks for these requirements. It is the responsibility of the host software to insure these restrictions are adhered to.

If a frequency setting less than 3.00MHz is received by the R-505C, or if a frequency greater 1002.00MHz is received, this command will be ignored.

If in BC Block Converter mode the valid range is .3MHz to 300MHz.

HOST: [1] = upper 8 bits of (frequency/100)
 [2] = middle 8 bits of (frequency/100)
 [3] = lower 8 bits of (frequency/100)

R-505C: FLAG BIT#1 = 1, if invalid frequency

COMMAND 23

Download Motorola ASCII S-records to the E²PROM. The only valid S-record types are S1 and S9 (see a Motorola data manual for details on S-record definitions). The R-505C will respond to this command and then wait for S-records to be sent. Upon error (i.e. data overrun, invalid checksum, etc.) or reception of an S9 record, the R-505C will exit this state and resume looking for RS-232 commands.

The R-505C does not use the address of the S9 record. An S9 record simply designates the end of the S-record file transmission.

HOST:

R-505C:

COMMAND 27

Stores the present meter state in one (1) of the 41 memory set-ups with the following exception:

- does not store the remote communications state

Memory # 0 is the power-up state of the meter. #1-40 are the 40 USER MEMORY locations.

HOST: [1] = memory # to store (0-40)

R-505C: FLAG BIT # 1 = 1, if invalid memory #

COMMAND 28

Reads one (1) of the eight (8) analog-to-digital (a/d) channels. Returns the average 10-bit reading.

The following is the a/d channel assignment:

- 1) rf signal level
- 2) internal temperature
- 3) external temperature (probe must be attached)
- 4) leakage squelch
- 5) battery voltage
- 6) (undefined)
- 7) (undefined)
- 8) (undefined)

HOST: [1] = a/d channel # (0-7)

[2] = # of readings to average (1-63)

R-505C: [1] = a/d channel # read

[2] = # of readings averaged

[3] = upper 2 bits of 10-bit a/d average

[4] = lower 8 bits of 10-bit a/d average

FLAG BIT #1 = 1, if invalid a/d channel #
or invalid # of readings

Section 9: Serial Command Protocol

COMMAND 29

Report certain meter conditions. Bits in the 1st response byte indicate that conditions true, as shown below.

HOST:

R-505C: [1] = BIT #0 - field strength meter state
 #1 - leakage meter state (not used in R-505C)
 #2 - remote communications state
 #3 - channel/video tuning state
 #4 - channel/audio tuning state
 #5 - frequency tuning state
 #6 - user memory tuning state

if field strength meter state:

[2] = upper 8 bits of fsm frequency
[3] = middle 8 bits of fsm frequency
[4] = lower 8 bits of fsm frequency

or if leakage meter state:

[2] = upper 8 bits of leakage frequency
[3] = middle 8 bits of leakage frequency
[4] = lower 8 bits of leakage frequency
[5] = firmware version number
[6] = firmware version # month
[7] = firmware version # year
[8] = BAUD rate (4=1200)(5=2400)(7=9600)

COMMAND 30

Resets the R-505C. Simulates a power-up condition.

(NOTE: The R-505C will no longer be in remote state.)

HOST:

R-505C: (no response)

COMMAND 31

Forces the R-505C to go to field strength meter state while remaining in remote communications state.

HOST:

R-505C:

COMMAND 32

Unlocks the attenuator range. Allows auto ranging.

HOST:

R-505C:

COMMAND 33

Read the year offset from 1992 (Examples: 1992 = 0; 1993 = 1; etc.)

HOST:

R-505C: [1] = year offset

COMMAND 34

Set the year offset from 1992 (Examples: 1992 = 0; 1993 = 1; etc.)

HOST: [1] = year offset

R-505C: [1] = year offset

COMMAND 35

Read the signal level of the currently tuned frequency (as normally shown on the meter display). Units will be in dBuV.

HOST:

R-505C: [1] = upper 8 bits of reading

 [2] = lower 8 bits of reading

COMMAND 36

(Factory use only. Do not use this command.)

COMMAND 37

Enables/disables the detector calibration correction. Assumes there is valid detector calibration data in the E²PROM. If the meter is not calibrated, this command has no effect.

HOST: [1] = 0, if disable

1, if enable

R-505C: [1] = 0, if disabled

1, if enabled

COMMAND 38

Enables/disables the frequency calibration correction. Assumes there is valid frequency calibration data in the E²PROM. If the meter is not calibrated, this command has no effect.

HOST: [1] = 0, if disabled

1, if enable

R-505C: [1] = 0, if disabled

1, if enabled

COMMAND 39

Enables/disables the temperature calibration correction. Assumes there is valid temperature calibration data in the E²PROM. If the meter is not calibrated, this command has no effect.

HOST: [1] = 0, if disable

1, if enable

R-505C: [1] = 0, if disabled

1, if enabled

COMMAND 40

(Factory use only. Do not use this command.)

COMMAND 42

(Factory use only. Do not use this command.)

COMMAND 43

Sets/reads all four (4) of the 6-bit digital-to-analog channels (DAC). If it is desired to leave a DAC channel's

This command is not recommended for customer use. Improper usage could result in unpredictable results.

HOST:	[1] = new DAC #1 setting (0-63)
	[2] = new DAC #2 setting (0-63)
	[3] = new DAC #3 setting (0-63)
	[4] = new DAC #4 setting (0-63)
R-505C:	[1] = present DAC #1 setting (0-63)
	[2] = present DAC #2 setting (0-63)
	[3] = present DAC #3 setting (0-63)
	[4] = present DAC #4 setting (0-63)

COMMAND 44

Writes up to 13 bytes of 8-bit data to sequential addresses in the RAM or E2PROM of the R-505C.

This command is not recommended for customer use. Improper usage could result in unpredictable results.

HOST:	[1] = number of bytes to change (1-13)
	[2] = upper 8 bits of starting address
	[3] = lower 8 bits of starting address
	[4] = 1st 8-bit data byte
	.
	.
	[16]= 13th 8-bit data byte
R-505C:	[1] = number of bytes changed
	[2] = upper 8 bits of starting address
	[3] = lower 8 bits of starting address
	[4] = 1st 8-bit data byte

Section 9: Serial Command Protocol

[16] = 13th 8-bit data byte

COMMAND 45

Selects a CHANNEL PLAN for command #46 to use. The meter will not allow an unlearned LEARN channel plan to be selected.

HOST: [1] = channel plan #
 1 = NCTA, PAL B/G, PAL D/K, JAPAN, EI
 2 = HRC, UK-1, PAL 300
 4 = IRC, UK-2, PAL 470
 8 = AIR, UHF
 16 = L1
 32 = L2
 64 = USER

R-505C: [1] = current channel plan # (after setting)
 [2] = upper 8 bits of the tuned frequency
 [3] = middle 8 bits of the tuned frequency
 [4] = lower 8 bits of the tuned frequency

COMMAND 46

Starts a CHANNEL PLAN DATA LOGGING session. The maximum scan frequency is represented in 100 Hz units. For example, 325.5MHz would be represented as 3255000. The log interval is the amount of time to expire after the start of a data log record until the start of the next data log record. It must be between one (1) and 360 minutes. If a single record is desired, the 7th data byte must be zero (0). If the 7th byte is zero (0), the data log record will be taken immediately and returned to the host. If the 7th byte is non-zero, records will be taken on a continual basis, starting at the start time and date, until any command is received from the host. When all 24 records are stored, the record counter resets to the 1st record and continues to store records. This way, only the most current 24 records are retained.

The 8th through 11th data bytes (if used), must be in 4-bit BCD representation. For example, 15 hours would have a 1 in the upper 4 bits of the 8-bit byte and a 5 in the lower 4 bits. The resulting hexadecimal value for the 8th data byte would be 15.

HOST: [1] = upper 8 bits of the maximum scan frequency

- [2] = middle 8 bits of the maximum scan frequency
- [3] = lower 8 bits of the maximum scan frequency
- [4] = upper 8 bits of log interval (minutes)
- [5] = lower 8 bits of log interval (minutes)
- [6] = log mode (=0 - 10 USER MEMORY log)
(!0 - channel plan log)
- [7] = eternal (=0 - take 1 record only)
(!0 - loop all 24 forever)
- [8] = 1st log 24-hour start time (hours)
- [9] = 1st log 24-hour start time (minutes)
- [10] = 1st log start date (day)
- [11] = 1st log start date (month)

R-505C:

COMMAND 47

Starts a CONTIGUOUS DATA LOGGING session. The beginning and ending scan frequencies are represented in 100Hz units. For example, 1.65MHz would be represented as 16500. The log interval is the amount of time to expire after the start of a data log record until the start of the next data log record. It must be between 5 and 1440 minutes (24 hours). If a single record is desired, the 9th data byte must be zero (0). If the 9th byte is zero (0), the data log record will be taken immediately and returned to the host. If the 9th byte is non-zero, records will be taken on a continual basis, starting at the start time and date, until any command is received from the host. When 20 records are stored, the record counter resets to the 1st record and continues to store records. This way, only the most current 20 records are retained.

The 11th through 14th data bytes (if used), must be in 4-bit BCD representation. For example, 17 hours would have a 1 in the upper 4 bits of the 8-bit byte and a 7 in the lower 4 bits. The resulting hexadecimal value for the 11th data byte would be 17.

- HOST:
- [1] = upper 8 bits of the beginning scan frequency
 - [2] = middle 8 bits of the beginning scan frequency
 - [3] = lower 8 bits of the beginning scan frequency
 - [4] = upper 8 bits of the ending scan frequency
 - [5] = middle 8 bits of the ending scan frequency

Section 9: Serial Command Protocol

- [6] = lower 8 bits of the ending scan frequency
- [7] = upper 8 bits of log interval (minutes)
- [8] = lower 8 bits of log interval (minutes)
- [9] = eternal (=0 - take 1 record only)
(!0 - loop all 20 forever)
- [10] = frequency step / 10kHz
- [11] = 1st log 24-hour start time (hours)
- [12] = 1st log 24-hour start time (minutes)
- [13] = 1st log start date (day)
- [14] = 1st log start date (month)

R-505C:

COMMAND 55

Sets the RF Amplifier, and IF BANDWIDTH.

HOST: [1] = 0 RF Amp off
 1 RF Amp on
 [2] = 0 Wideband
 1 Narrowband

R-505C:

COMMAND 57

Mutes the R-505C Audio.

HOST: [1] = 0 Mute Audio
 1 unMute Audio
R-505C:

COMMAND 60

Sets four (4) frequencies, in EEPROM, for remote command #61 to use.

Frequency data must be a multiple of 10kHz. Also, the frequency data, in Hz, must be divided by 100 before transmission. The R-505C does not perform checks for these requirements. It is

the responsibility of the host software to insure these restrictions are adhered to. If a frequency setting less than 0.300MHz is received by the R-505C, or if a frequency greater than 1002.00MHz is received, this command will be ignored.

- HOST:
- [1] = upper 8 bits of (frequency_A / 100)
 - [2] = middle 8 bits of (frequency_A / 100)
 - [3] = lower 8 bits of (frequency_A / 100)
 - [4] = upper 8 bits of (frequency_B / 100)
 - [5] = middle 8 bits of (frequency_B / 100)
 - [6] = lower 8 bits of (frequency_B / 100)
 - [7] = upper 8 bits of (frequency_C / 100)
 - [8] = middle 8 bits of (frequency_C / 100)
 - [9] = lower 8 bits of (frequency_C / 100)
 - [10] = upper 8 bits of (frequency_D / 100)
 - [11] = middle 8 bits of (frequency_D / 100)
 - [12] = lower 8 bits of (frequency_D / 100)
- R-505C
- [1] = upper 8 bits of (frequency_A / 100)
 - [2] = middle 8 bits of (frequency_A / 100)
 - [3] = lower 8 bits of (frequency_A / 100)
 - [4] = upper 8 bits of (frequency_B / 100)
 - [5] = middle 8 bits of (frequency_B / 100)
 - [6] = lower 8 bits of (frequency_B / 100)
 - [7] = upper 8 bits of (frequency_C / 100)
 - [8] = middle 8 bits of (frequency_C / 100)
 - [9] = lower 8 bits of (frequency_C / 100)
 - [10] = upper 8 bits of (frequency_D / 100)
 - [11] = middle 8 bits of (frequency_D / 100)
 - [12] = lower 8 bits of (frequency_D / 100)

- or -

FLAG BIT #1 = 1, if any frequency is invalid

COMMAND 61

Reads the signal levels of the four (4) command #60 frequencies. Applies calibration correction, if enabled. Units will be in dBuV.

HOST:

R-505C: [1] = upper 8 bits of frequency_A reading
 [2] = lower 8 bits of frequency_A reading
 [3] = upper 8 bits of frequency_B reading
 [4] = lower 8 bits of frequency_B reading
 [5] = upper 8 bits of frequency_C reading
 [6] = lower 8 bits of frequency_C reading
 [7] = upper 8 bits of frequency_D reading
 [8] = lower 8 bits of frequency_D reading

COMMAND 62

Sets the frequency for the field strength meter state and reads the signal level. Applies calibration correction, if enabled. Units will be in dBuV.

Frequency data must be a multiple of 1kHz. Also, the frequency data, in Hz, must be divided by 100 before transmission. The R-505C does not perform checks for these requirements. It is the responsibility of the host software to insure these restrictions are adhered to. If a frequency setting less than 0.300MHz is received by the R-505C, or if a frequency greater than 1002.00MHz is received, this command will be ignored.

HOST: [1] = upper 8 bits of (frequency / 100)
 [2] = middle 8 bits of (frequency / 100)
 [3] = lower 8 bits of (frequency / 100)

R-505C: [1] = upper 8 bits of reading
 [2] = lower 8 bits of reading

- or -

FLAG BIT #1 = 1, if invalid frequency

Section 10: Quick Reference Card

R-505C BASIC OPERATING INSTRUCTIONS

- ◆ TURN POWER ON USING **POWER** BUTTON
- ◆ TOP LINE OF LCD DISPLAY IS **SIGNAL LEVEL** READOUT.
- ◆ MIDDLE LINE OF LCD DISPLAY IS **FREQUENCY/CHANNEL** READOUT.
- ◆ BOTTOM LINE OF LCD DISPLAY IS **STATUS** READOUT.
- ◆ ADJUST **TUNE** KNOB FOR FREQUENCY TO BE MEASURED. PUSHING **TUNE** KNOB CHANGES DETENTS VERSUS FREQUENCY STEPS.
- ◆ WHEN THE METER IS RECEIVING A SIGNAL WITHIN ITS AUTO-RANGE CONTROL THE **SIGNAL LEVEL** READOUT WILL BE STABLE AND THE '<' or '>' SIGN IN THE **SIGNAL LEVEL** READOUT WILL NOT BLINK.
- ◆ WHEN THE '<' or '>' SIGN BLINKS, INPUT SIGNAL IS OUT OF THE AUTO-RANGE CONTROL. IF THE INPUT SIGNAL IS TOO SMALL, ADD GAIN BY PRESSING THE **RF AMP** BUTTON.
- ◆ TWO IF **BANDWIDTH** FILTERS ARE AVAILABLE SELECTABLE BY THE **BANDWIDTH** BUTTON
- ◆ "**WB**" HAS A BANDWIDTH OF 150 kHz
- ◆ "**NB**" HAS A BANDWIDTH OF 15 kHz
- ◆ TO ACCURATELY MEASURE SIGNALS BELOW 0 dBuV, THE "**NB**" IF FILTER MUST BE USED.
- ◆ WHEN **FREQ/CH** BUTTON IS SELECTED, EVERY DETENT OF THE **TUNE** KNOB CHANGES THE RECEIVED FREQUENCY BY ONE CHANNEL.
- ◆ **FUNCTION** BUTTON ALLOWS USER TO ACCESS MANY HELPFUL METER FUNCTIONS. (SEE THE OTHER SIDE OF THIS CARD).
- ◆ **MEMORY** BUTTON ALLOWS USER TO STORE UP TO 10 FREQUENTLY USED FREQUENCIES OR CHANNELS. AFTER SELECTING, **MEMORY** EACH DETENT OF THE **TUNE** KNOB CHANGES THE METER TO THE NEXT STORED USER MEMORY FREQUENCY OR CHANNEL.
- ◆ **IMPORTANT NOTE:** EVERY TIME A NEW SIGNAL IS MEASURED ALWAYS START WITH THE **RF AMP** OFF. USE THIS AMPLIFIER ONLY WHEN THE SIGNAL TO BE MEASURED IS OTHERWISE TOO SMALL.

Section 10: Quick Reference Card

Function Listing and Description

F1	BATTERY VOLTAGE CHECK	
F3	CUSTOMER CALIBRATION (MINOR)	
F4	VIEW CHANNEL PLAN	
F5	DISABLE AUTO POWER DOWN	
F7	SET SCAN STEP FREQUENCY	
F8	SET SCAN START FREQUENCY	(Frequently accessed functions)
F9	SET SCAN STOP FREQUENCY	
F10	AUTO - CONTIGUOUS RESIDENT DATA LOGGING	
F11	MANUAL - CONTIGUOUS RESIDENT DATA LOGGING	
F15	SELECT ATTENUATOR SETTING	
<hr/>		
F21	ERASE USER MEMORY (1 - 40)	
<hr/>		
F28	SOFTWARE VERSION #	
<hr/>		
F40	CUSTOMER CALIBRATION (MAJOR)	
F41	SELECT CUSTOMER CALIBRATION	
F42	SELECT FACTORY CALIBRATION	
F43	SET RS-232 BAUD RATE	
F44	SET RS-232 REMOTE ADDRESS	(Locked out User Functions)
F45	SET 24 HOUR CLOCK	{Except F44}
F46	SET MONTH/DAY	
F47	SET YEAR	
F48	CLONE ANOTHER R-505C	
<hr/>		
F59	UNLOCK USER FUNCTIONS F40 - F48	
<hr/>		
F91	RESET DATA LOG RECORD COUNTER TO 1	
F93	REMOTE MODE	
F94	PRINT (RS-232) SELECTED DATA LOG RECORD	
F95	PRINT (RS-232) ALL DATA LOG RECORDS	
F96	AUTO - USER MEMORY RESIDENT DATA LOGGING	(Data Logging Functions)
F98	MANUAL - USER MEMORY RESIDENT DATA LOGGING	

Section 11: Block Diagram

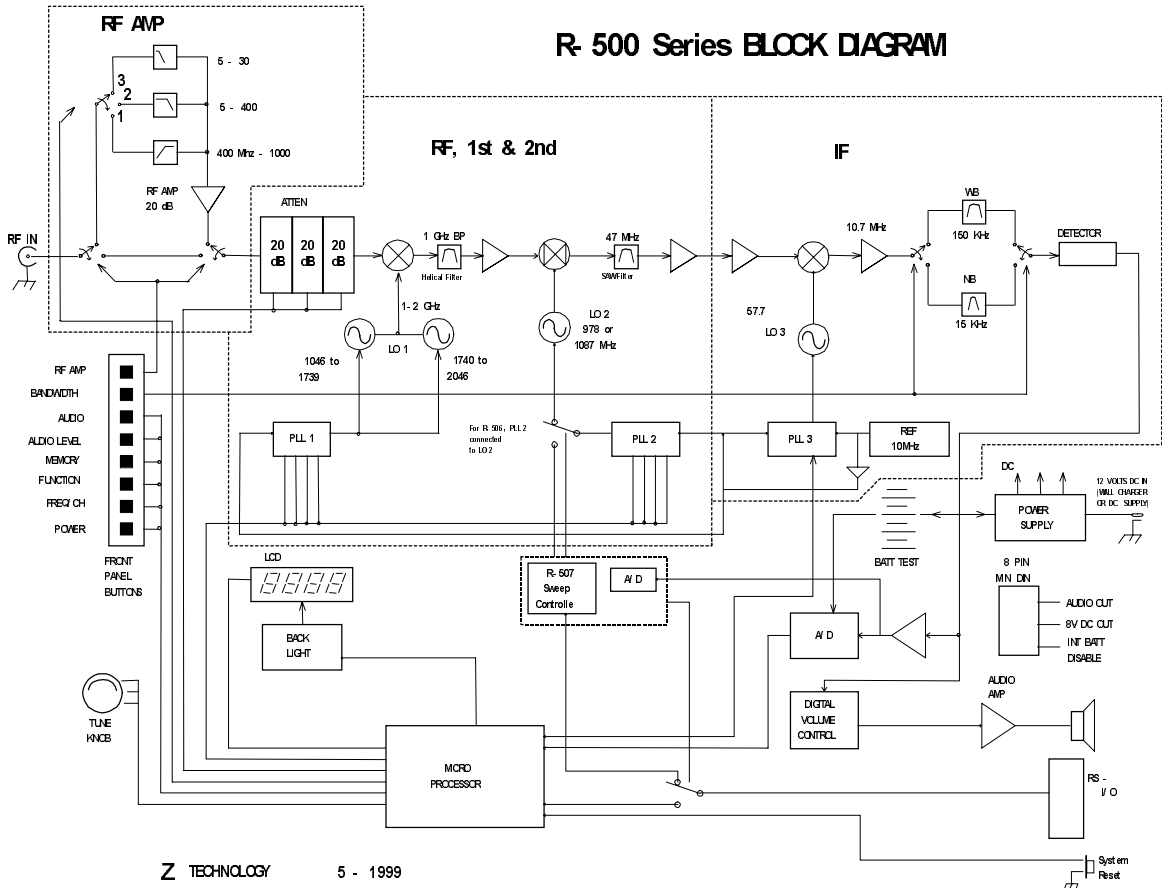

Section 12: Rear Panel connectors

The rear panel of the R-505C has four connectors: looking at the rear panel from left to right they are: an RS-232 serial port, an External Battery Input, an accessory connector and the receptacle plug for the charger/power supply. The accessory connector an 8 pin Mini - Din Female Connector.

A small hole to the right of the RS-232 serial port is a system-reset button. Should the meter fail to operate properly, disconnect any External Charger/Supply then press the reset button with the tip of a sharp pencil, or the end of a paper clip. This will reset the meter.

The accessory connector is provided for the following uses:

For connecting an external 8 Ohm speaker	Pin 1 & Pin 2
Provides external + 8.8VDC at 50 ma. accessory power	Pin 3, Pin 4 is Ground
To allow the instrument to power up and operate only when the external power supply/charger is connected to the R-505C. (With these two pins open the unit will operate normally from either the internal Battery Pack or from the External Charger/Supply).	Short Pins 5 & Pin 7

The following Diagram shows pin numbers for the 8 Pin Mini-Din Connector.

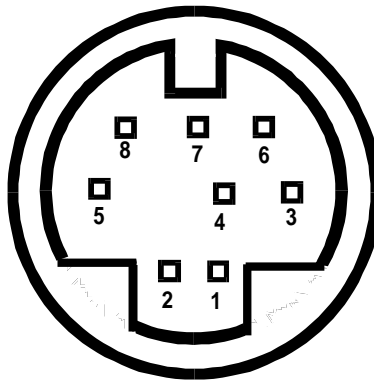

Section 12: Rear Panel connectors

Section 13: Addendum

ADDENDUMS & CORRECTIONS

Measurement Accuracy Statement: +/- 2 dB for CW signals: +15 to +35 Deg C
+/- 2 dB Typical: 0 to +50 Deg C

- a) Modulation may influence measurement accuracy. For instance, for video modulation, the instrument measures signal strength of the Vertical Sync Peak. This adds 0.5 dB of additional uncertainty, to measurement accuracy.
- b) Each instrument is verified to be within the stated accuracy specification shown above as referenced to a CW signal. Each instrument is also calibrated over temperature to provide added accuracy through the range of 0 to 50 Deg C.
- c) Stated accuracy numbers are referenced to a very accurate signal source. The signal source itself has NIST Traceable accuracy to better than +/- 0.5dB. All inaccuracies are additive including reference signal source inaccuracy and the above measurement accuracy numbers.

Corrections:

- 1) In Narrowband IF mode, the standard instrument is specified to have a "typical" measurement accuracy of +/-2 dB from -10 dBuV to 0 dBuV over temperature.
- 2) In Wideband IF mode, at frequencies above 5 MHz, the standard instrument and all options are specified to have a "typical" measurement accuracy of +/- 2 dB for the lowest 10 dB of each measurement range. This is true for both the RF AMPLIFIER "ON" and "OFF" settings. This holds for the instrument's specified temperature range.
- 3) Some users of the R-506 may notice a few small signals (around 0dBuV) at or near the following frequencies:
 - 8 MHz
 - 16 MHz
 - 30 to 80 MHz

These signals are due to internal signal sources such as reference crystals and microprocessor switching transients. They remain constant and are only found when an external antenna is attached to the Type-N input connector and held close to the instrument.